



NEW 50 SERIES

driving/maintenance handbook

RENAULT

Trucks

This new vehicle conforms to regulations currently in force.

Consequently, any subsequent replacement of RENAULT TRUCK INDUSTRIES parts by parts from a different source may result in the vehicle not being in accordance with these regulations.

Fitting of such replacement parts will also invalidate the warranty.

You are reminded that original RENAULT TRUCK INDUSTRIES components have been designed, manufactured and inspected to ensure maximum service life from the vehicle.

Drivers

This operator's handbook is intended particularly for your use.

It has been laid out to provide all the information you need and to ensure that you derive the maximum of benefit from it.

You are asked to read it carefully until you are completely familiar with the contents.

This handbook should be kept to hand in the glove box of your vehicle.

You are reminded that details can be obtained from your dealer regarding any special usage you may wish to make of your vehicle.

The manufacturer reserves the right to make any modifications deemed necessary during production. Therefore, this handbook cannot be taken as a specification for a particular model.

RENAULT

Trucks



Renault Truck Industries Limited

Boscombe Road, Dunstable, Bedfordshire LU5 4LX

Tel 0582 471122 Telex 82191

driving maintenance

contents

	Pages
ALPHABETICAL INDEX	2
SPECIFICATIONS	5
EQUIPMENT	9
DRIVING	24
WARRANTY INSPECTION - LUBRICATION SERVICING SCHEDULES	31
SERVICING	40
ELECTRICAL EQUIPMENT	72

	Pages		
A		Driving	24
Alternator	74	Drum brakes	71
Air cleaner	41	E	
Air line filter	66	Emergency charging air system	65
Air reservoir	65	Engine access (bonnet release)	13
Air restriction indicator	41	Engine covers	14
Air system	64	Engine – diesel	44
Anti-freeze	39-43	Engine – petrol	49
Auto. transmission	28-57	Engine speed adjustment	48
B		F	
Battery	72	Fuel filter – diesel	46
Bleeding fuel system	47	Fuel filter – petrol	50
Brake antifreeze	22	Fuel injection pump	48
Brake fluid level	68	Fuel pump – diesel	45
Brakes	70	Fuel pump – petrol	49
Brake system	64	Fuses	74
Brake warning light and buzzer	27-69	G	
Bodywork	6	Gearbox – automatic	57
Bonnet release	13	Gearbox – manual	56
Bulbs	75	Gear changing – manual	27
C		Gear selection – automatic	28
Cab protection	31	H	
Capacities	7	Handbrake	26-71
Carburettor	51	Headlamp adjustment	76
Clutch	55	Heating and ventilation	16
Cold starting	25	Hydraulic system	55-68
Cooling system	42	I	
D		Ignition switch	24
Dampers	63	Ignition system	51-52
Diesel engine	44	Injectors	48
Disc brakes	70	Instrument panel	9-10
Doors and windows	11		
Drive belts	53		

J		
Jump starting	73	
K		
L		
Lighting switches	23	
Load sensing valve	69	
Lubricants	38	
M		
N		
O		
Oil changing	40	
Oil filters	40	
Operator checks	33	
P		
Parking brake	26	
Petrol engine	49	
Power steering	62	
Propeller shaft	58	
Q		
R		
Rear axle	59	
Rear doors	12	
Running in	27	
S		
Safety belts	15	
Safety operations	32	
Seats	12	
Servicing schedules	33	
Sound insulation	14	
Spare wheel	19	
Sparking plugs	52	
Specifications	5	
Spring brake	67	
Starter switch	24	
Starting	25	
Steering column switch	23	
Steering – manual	61	
Steering – power	62	
Stopping	25	
Suspension	63	
T		
Tyre pressures	8	
Tyres	20	
Towing	30	
U		
V		
Vacuum system	64	
Ventilation	16	
W		
Wheel fitting instructions	18	
Wheels	19	
Windscreen wipers and washers	21	
Water trap	44	
X		
Y		
Z		

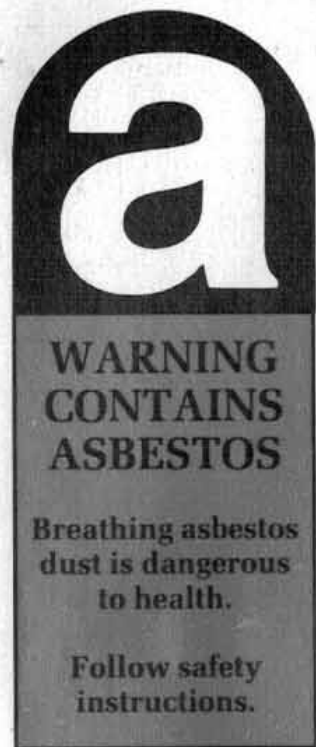

ASBESTOS ALERT

The vehicle described in this publication incorporates components containing asbestos.

Working with them can create dust. Breathing this dust is harmful. Cases of asbestos related cancer have been reported in garage workers.

The dangerous jobs are: • cleaning brake assemblies • cleaning clutch housings • grinding brake linings • drilling brake linings • sweeping floors

Brake and clutch linings and disc pads may contain asbestos. If in doubt assume that they do.

WHO IS AT RISK?

Anyone in the garage could be at risk. There is no known safe level of asbestos dust. But the more dust you breathe the greater the chance of lung damage.

The problem is that the dust particles are too small to be seen by the naked eye. And the diseases caused can take years to develop.

Don't put the brakes on your life. Avoid breathing asbestos dust. Prevent dust getting into the air. Follow the GARAGE WORKERS' ASBESTOS CODE.

GARAGE WORKERS' ASBESTOS CODE

1. DON'T blow dust out of brake drums or clutch housings with an air line.
2. DO use properly designed drum cleaning equipment which prevents dust escaping, or use clean wet rags to clean out drums or housings. Put used rags in a plastic waste bag while still wet.
3. DON'T grind or drill linings unless the machine has exhaust ventilation or there is a ventilated booth to do the work in.
4. DON'T use brushes to sweep up dust.
5. DO use a special (Type H) vacuum cleaner to remove dust.
6. DO wet dust *thoroughly* and scrape it up if you haven't got a vacuum.
7. DO wear the protective clothing, such as overalls, provided by your employer.
8. DON'T take the protective clothing home. It should be cleaned by your employer.
9. DON'T use equipment if it is not maintained and checked. Ask to see the examination reports for ventilation systems.

ENGINE

	Phaser 90
Capacity	4 litres
Bore/stroke	100/127mm
Injection pump	Bosch EPVE
Firing order	1,3,4,2
Max r.p.m.	2800
Idling speed r.p.m.	625

	Phaser 110T
Capacity	4 litres
Bore/stroke	100/127mm
Injection pump	Bosch EPVE
Firing order	1,3,4,2
Max r.p.m.	2600
Idling speed r.p.m.	625

	6.225 Petrol
Capacity	3,684 litres
Bore/stroke	86,36/104,78mm
Carburettor	Holley 6R6038B
Firing order	1,5,3,6,2,4
Spark plugs	RBL 11Y (Gap 0.035 ins. 0,90mm)
Max r.p.m.	3600
Idling speed r.p.m.	800

CLUTCH

A.P.	280 DS
A.P.	310 DS

GEARBOX

ZF	S5-24/3
Spicer	T5-290
Chrysler (auto)	A727

PROP SHAFTS

Tubular shafts fitted with universal joints.

REAR AXLE

Spiral bevel	AX6
Spiral bevel	AX8
Spiral bevel	AX9

FRONT AXLE

Reversed Elliot 'T' beam

STEERING

Manual	Burman recirculating ball
Power	ZF 8090

FRONT SUSPENSION

Symmetrical single leaf parabolic
Telescopic dampers

REAR SUSPENSION

Symmetrical minimum leaf semi-elliptic
Telescopic dampers

BRAKES

Vacuum/hydraulic

Front	Disc
Rear	Drum

Air/hydraulic

Front	Drum
Rear	Drum

specifications

BODYWORK

It is essential to obtain chassis drawings from your dealer when fitting bodywork or special equipment (loading crane, fifth wheel, etc.). For the attachment of this bodywork or equipment and also electrical connections, we require manufacturers and body-builders to comply with RENAULT specifications and standards drawn up for this purpose. These are readily available from S.E.O. Department, Dunstable.

Welding on vehicle

Important precautions:

The vehicle is equipped with numerous electronic circuits: alternator, voltage regulator, flasher unit, etc.

Prior to carrying out any electric welding work, disconnect the negative (-) and positive (+) cables from the terminals of the battery.

Place the earthing clamp as close as possible to the weld, but never attach it to a rotating part (prop shaft, hub, fan, etc.), nor to any sub-assembly having moving parts (air compressor, turbo-charger, etc.).

Nearby plastic pipes and electrical cables are to be protected or removed. This also applies for grinding or drilling.

When reconnecting the battery, respect the polarities by always beginning with the positive (+) terminal. If the polarity is reversed, you run the risk of causing irreparable damage to the electronic components.

ELECTRICAL

Battery 1 - 12V 128AH
(normal or H.D. version)

ALTERNATOR

Lucas A127 45 AMP. STD.
A127 65 AMP. H.D.

STARTER

Diesel

Lucas M127

Petrol

Chrysler Chrysler 4091975

CAPACITIES

Engine Oil

Litres

Phaser 90	10,05
Phaser 110T	10,56
6.225 Petrol	7,95

Cooling water

Phaser 90	17,90
Phaser 110T	18,35
6.225 Petrol	17,10

Gearbox

ZF S5-24/3	3,0
Spicer T5-290	4,5
Chrysler Auto A727	
Total	8,1
Refill	3,6

Rear Axle

AX6	2,84
AX8	4,546
AX9	4,545

Steering

Manual	0,5
Power	1,9

Clutch (fluid) 0,5

Fuel tank 85,0

Windscreen Wash Res. 4,0

Brakes (fluid) 1,75

specifications

TYRE PRESSURES

Tyre size all models : 205/75R17.5

MODEL	S35	S46	S56	S66	S75
PRESSURE	bar (psi)	bar (psi)	bar (psi)	bar (psi)	bar (psi)
FRONT	3.75 (54)	4.0 (58)	4.75 (69)	5.0 (73)	5.75 (83)
REAR	3.75 (54)	3.75 (54)	4.5 (65)	5.75 (83)	6.75 (98)

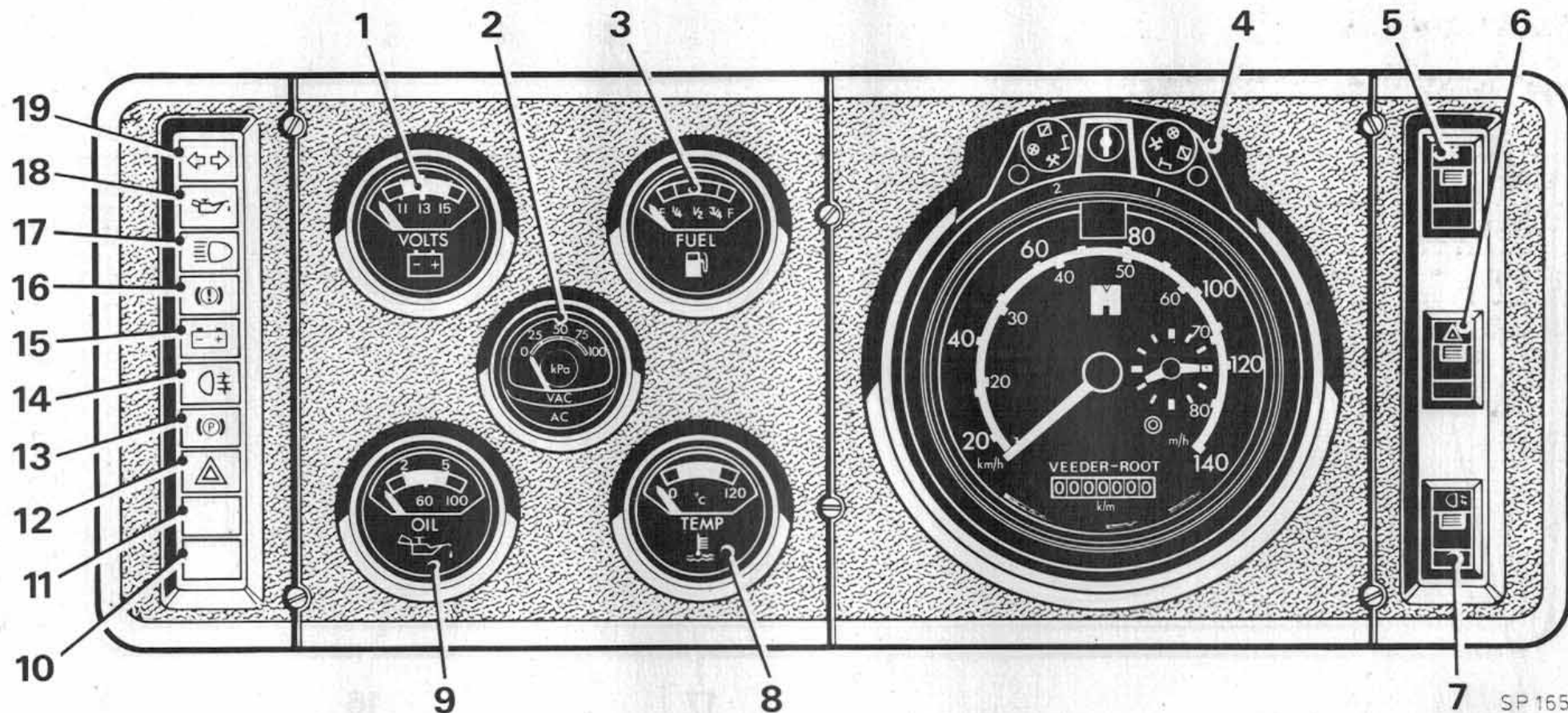

1. Voltmeter (option)
2. Vacuum or air gauge
3. Fuel gauge
4. Tachograph or speedometer
5. Blower switch
6. Hazard warning switch
7. Rear fog lamp switch
8. Temperature gauge
9. Oil pressure gauge (option)
10. Blank

11. Blank
12. Hazard warning
13. Parking brake & low air/vacuum
14. Rear fog light
15. No charge warning
16. Brake fluid level warning
17. Headlamp main beam
18. Oil pressure warning
19. Direction indicators

R.H.D. MODELS

SP 165

equipment

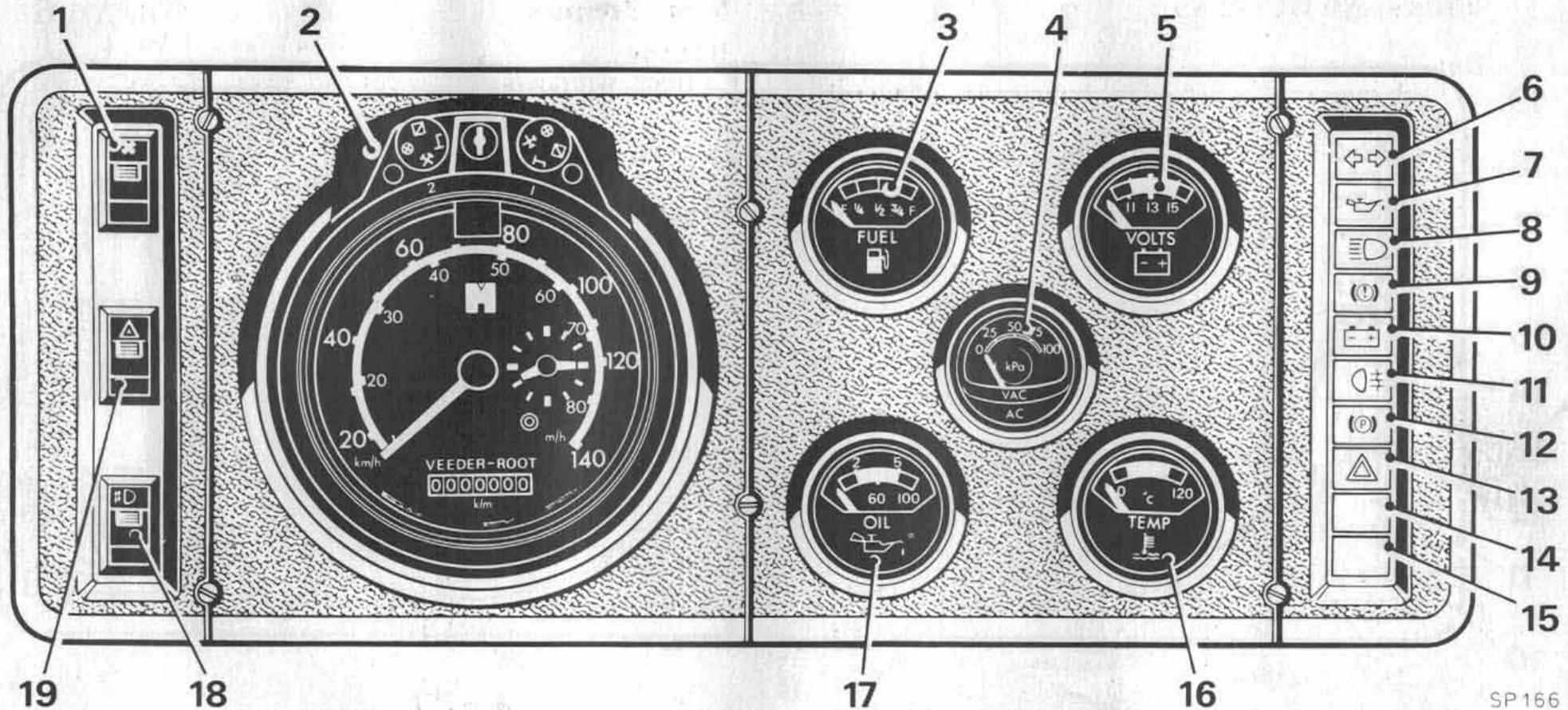

SP 166

1. Blower switch
2. Tachograph or speedometer
3. Fuel gauge
4. Vacuum or air gauge
5. Voltmeter (option)
6. Direction indicators
7. Oil pressure warning
8. Headlamp main beam
9. Brake fluid level warning
10. No charge warning

11. Rear fog light
12. Parking brake & low air/vacuum
13. Hazard warning
14. Blank
15. Blank
16. Temperature gauge
17. Oil pressure gauge (option)
18. Rear fog lamp switch
19. Hazard warning switch

L.H.D. MODELS

DOORS AND WINDOWS

Door Locks

Each door can be locked from the inside of the cab by depressing the locking catch 'B'. Alternatively both doors can be locked from the outside by means of the key.

Pulling the recessed door handle 'C' will automatically release the door lock.

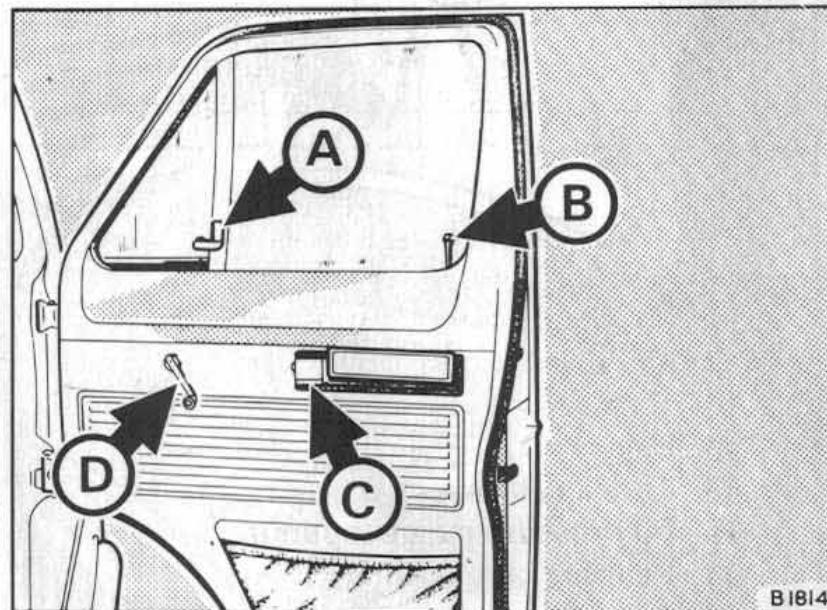

Door Windows

Window

Door windows are regulated by means of the window regulator handles 'D'

Quarter Light

To open the quarter light, lift the catch 'A' and rotate upwards.

Sliding Windows (high capacity van)

Depress the locking lever and slide the window forward. When closed ensure that the locking mechanism engages.

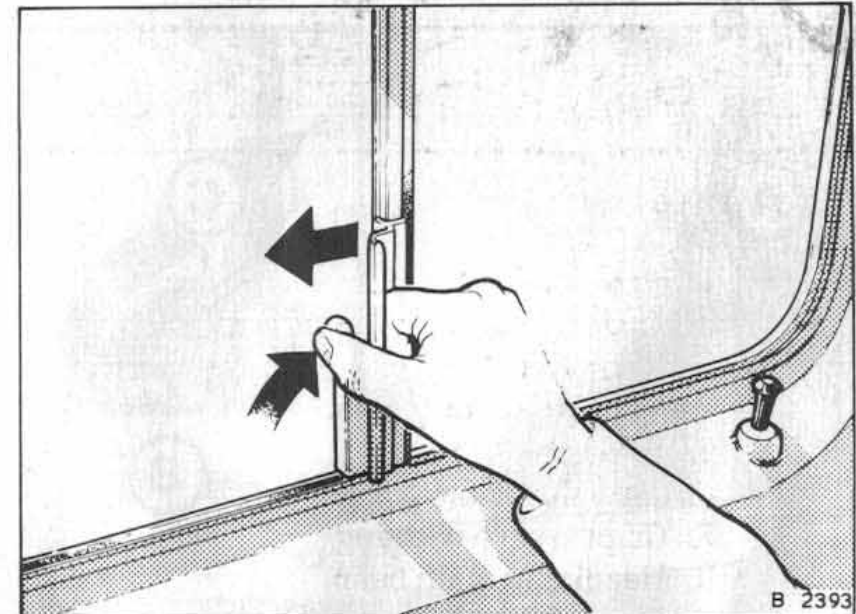

Van Rear Doors

An additional key is provided for locking the rear doors. The lock will not operate unless the outside handle has been returned to the secure position.

To retain the doors in the open position, locate the door stay (A) in the eye which is mounted on the door pillar.

The doors can be folded fully back against the sides of the van body after the door strap anchor pins (B) have been removed. Ensure that the catch pin (C) locates firmly in its retainer on the side of the van.

Do not drive the vehicle with the doors in this position. Reconnect the check straps before closing doors.

Cab Door Stays

Each door is fitted with a two stage door opening check catch operating at approximately 30° and 70° to the body side line.

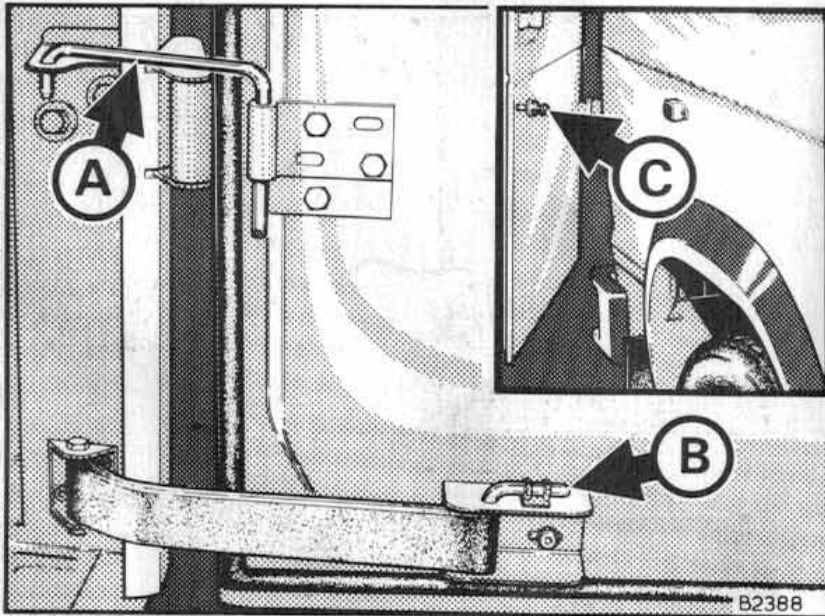

SEATS

Fore and Aft Adjustment

To move the seat either backwards or forwards operate the lever (C) sideways and push the seat to the desired position.

Passenger seat(s) are not adjustable.

Height Adjustment - Fully Adjustable Drivers' Seat

To raise or lower the seat rotate the handle (B) located at the front of the seat frame.

Back Rest (Rake Adjustment)

The angle of the back support can be adjusted by operating the lever (A) at the side of the squab.

Dual passenger seats are not adjustable for this movement.

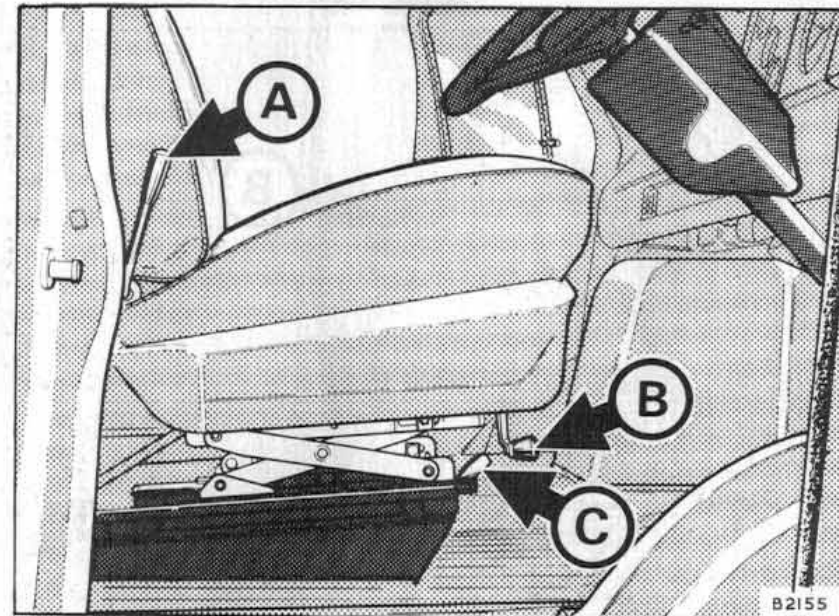

ENGINE ACCESS

From above

All service operations carried out from within the cab will necessitate removal of the engine cover.

When removing, release the toggle catches (A) securing the rear engine cover to the floor and front cover.

Additional access to the engine from the cab can be gained by removing the four set screws (B) securing the front cover.

For access to the front of the engine, pull the remote bonnet release beneath the passenger fascia, press the bonnet catch lever, lift the bonnet and retain by its stay.



Bonnet release

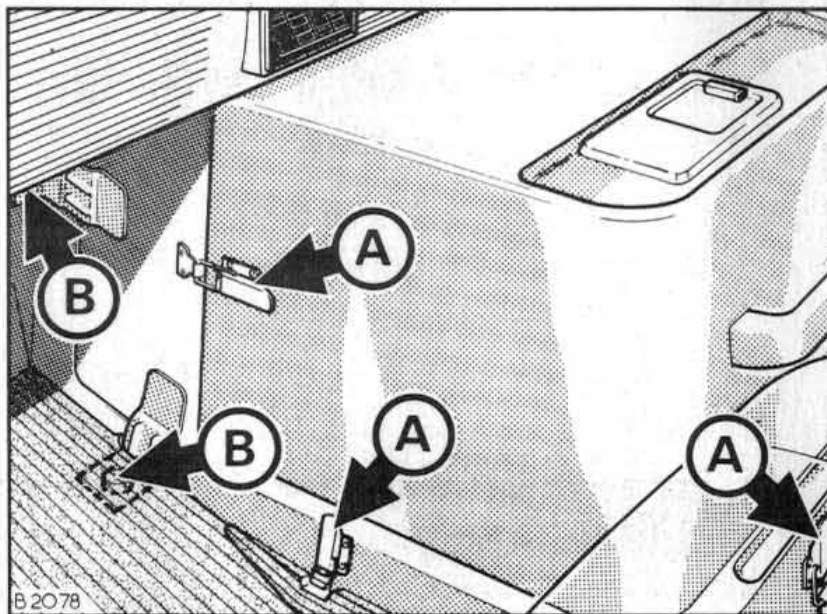

6 cylinder and T/C engine cover

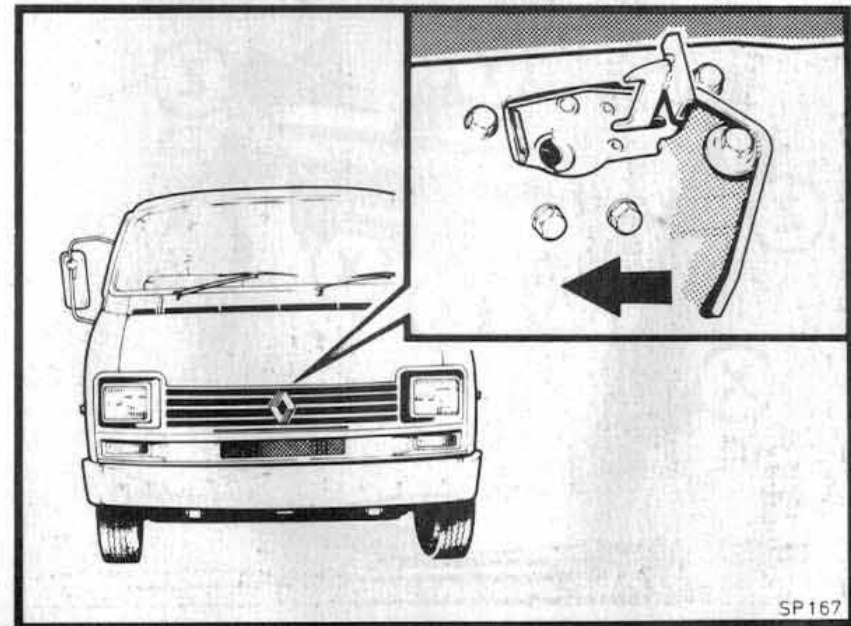

Safety catch

From below

Sound insulation trays are fitted under the engine.

Undertrays are retained by quick release fasteners and set screws.

To remove front undertray

Release the five quick release fasteners 'X' in illustration.

Squeeze the sides of the tray inwards at the top front to detach the tray from the locating dowels. Withdraw the tray.

To remove rear undertray

Remove the front undertray as previously explained.

Remove two setscrews 'Y' and release the two quick release fasteners 'Z'. Squeeze the sides of the tray, detach from the locating dowels and withdraw the tray.

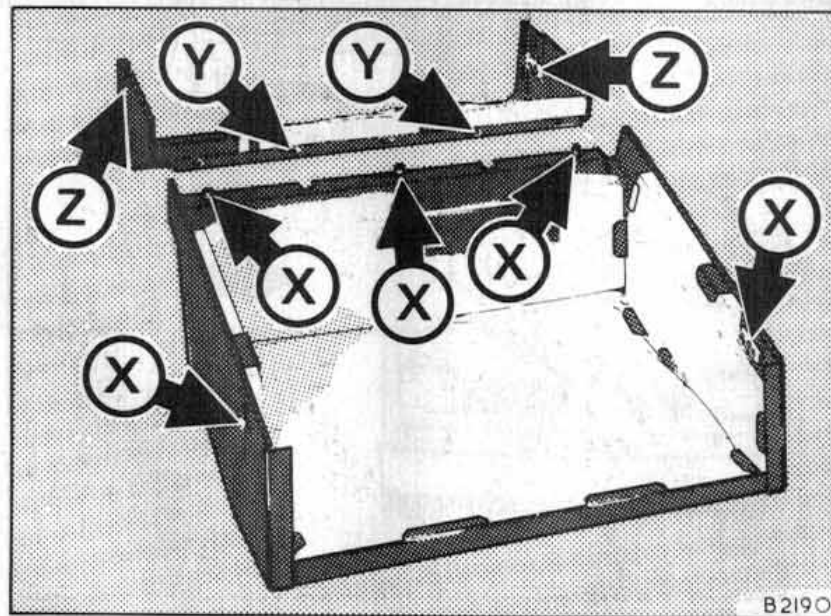

Rear undertray

SOUND INSULATION

Legislation

Sound insulation is fitted to your vehicle to ensure that its noise level remains within the legal limits.

Under no circumstances should the vehicle be operated without these panels.

Remember that badly contaminated insulation is a fire risk.

SAFETY BELTS

Inertia Reel Type (Driver and Single Seat Passenger)

To Fasten the Belt

Pull on the belt tongue at the upper attachment and position the belt, over the shoulder and hip, across the body. Push the belt tongue into the buckle stalk that is near the wearer until a positive click is heard, locking the tongue in position.

To Release the Belt

Depress the catch marked 'PRESS' on the buckle stalk and the belt will automatically be released and rewind itself into the reel.

Lap Type (Centre Passenger)

When a dual passenger seat is fitted the tongue portion of the lap type belt provided for the centre passenger will be found lying on the seat. The buckle stalk for this belt is located next to the seat.

To fasten or release the belt proceed as described for the inertia reel type.

To shorten the belt, pull the top portion of webbing (illustration A) through the adjuster. The correct tension should allow the hand to be inserted between the belt and the bony part of the hip.

To lengthen the belt, lift the adjuster (as illustrated in B) to approximately 45° thus allowing the webbing to pass through it.

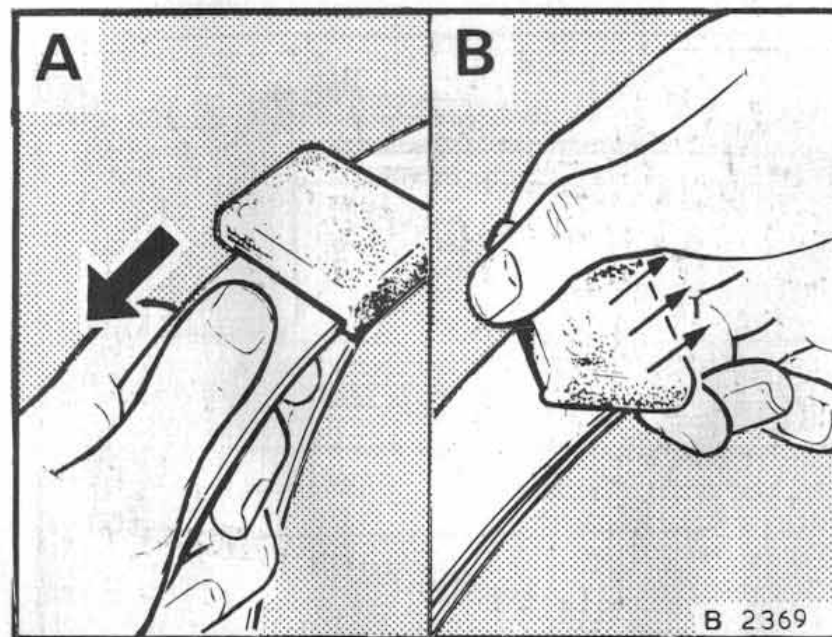

Lap type safety belt

HEATING AND VENTILATION

The heating and ventilation system is designed to provide fresh air to the screen, cab, face or feet at varying temperatures, regulated to individual requirements.

The system has the following controls:-

- Air distribution – screen (Demist)
- Air distribution – cab interior
- Temperature
- Face level vents
- Foot level vents
- Heater blower switch

Distribution Controls (1 and 2)

The controls located on the facia panel regulate air flow rate to the screen and cab interior.

Temperature Control (3)

Regulates the temperature of the air entering the cab, depending on its position between hot and cold positions.

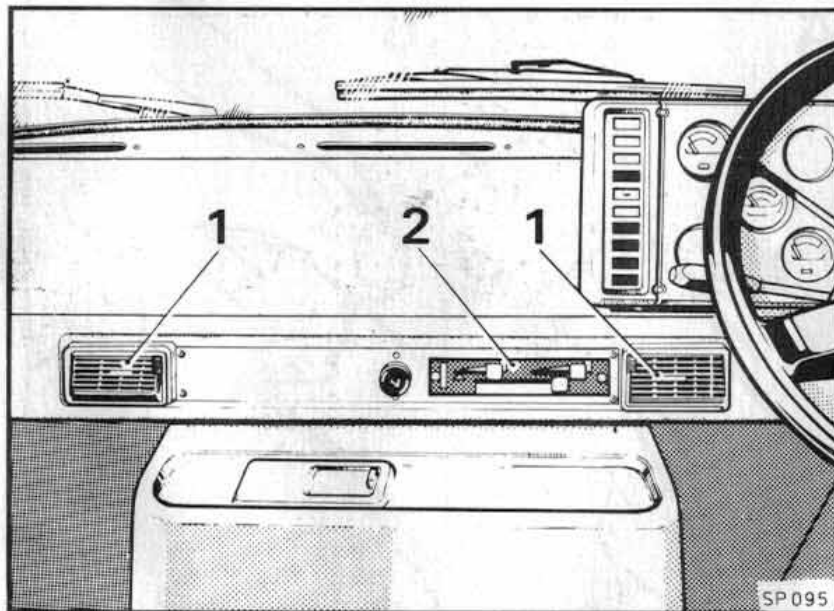

1 – Face vents 2 – Heater controls

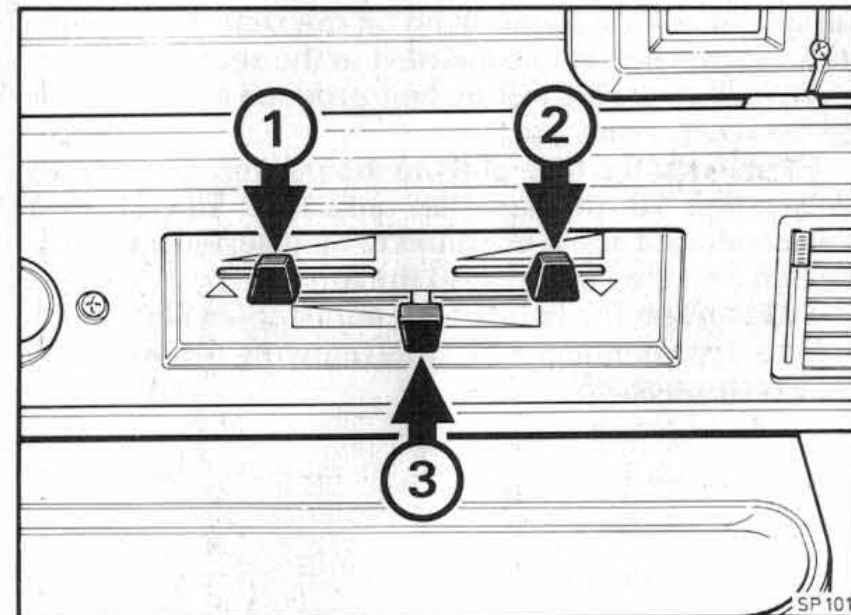

Heater and air controls

Face Level Vents

Controllable face level vents are located at each side of the heater control panel.

They direct a selected rate of unheated air flow to suit individual requirements.

Operating the vertical moving lever (2) controls air flow volume whilst the centrally positioned button (1) controls direction.

The heater blower may be used to boost the flow.
NOTE. For additional ventilation use the quarter lights (see under "Windows").

Blower Switch

The rocker type switch is mounted at the side of the instrument panel and is pressed when low or high boosted air flow is required for heating or ventilation.

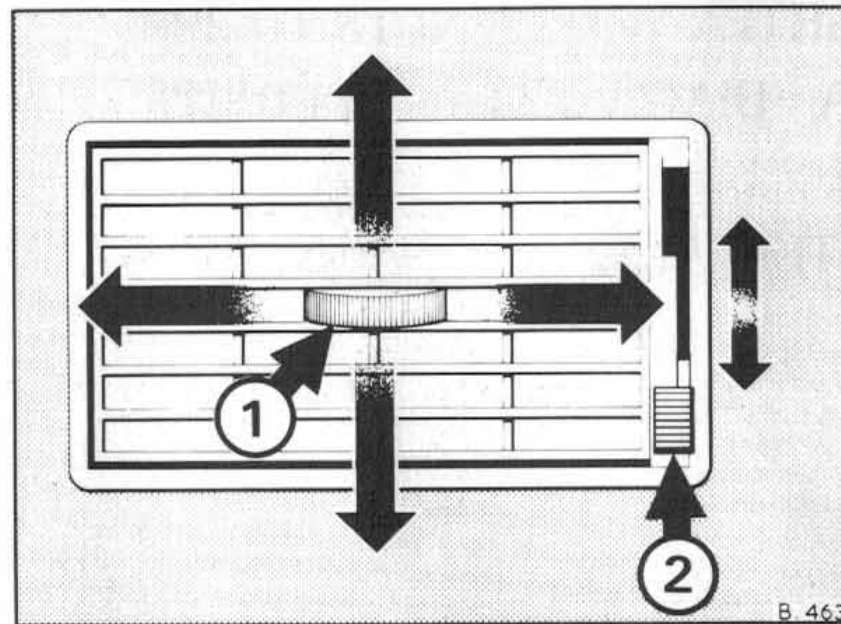

Face level vents

Foot Level Vents

These are located in the outer side panels of the foot wells.

Regulate the shutter type control to admit air flow to suit individual requirements.

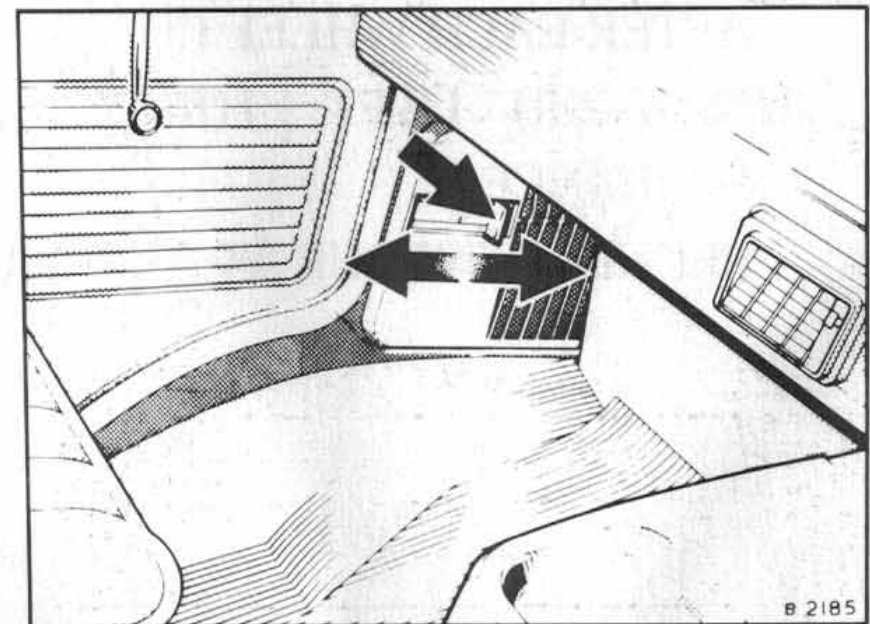

Foot level vents

WHEEL FITTING INSTRUCTIONS

**THIS VEHICLE IS FITTED WITH SPHERICAL SEAT WHEELS.
THE STUD THREADS ARE LEFT HAND ON THE LEFT SIDE AND
RIGHT HAND ON THE RIGHT SIDE.**

**AFTER EACH WHEEL CHANGE, TIGHTEN WHEEL NUTS TO 298
Nm. 220 LB.FT. TORQUE IN A DIAGONALLY OPPOSITE
SEQUENCE.**

RECHECK TORQUE AT REGULAR INTERVALS.

WHEELS

Tool Location

The wheelbrace, tommy bar and jack-operating lever are located on clips at the rear of the cab. The jack is located behind the drivers seat.

To Remove Spare Wheel - Truck Model

1. Using the spanner provided, remove the two nuts which secure the spare wheel to the chassis mounted bracket.
2. Wind down the spare wheel using the wheelbrace.

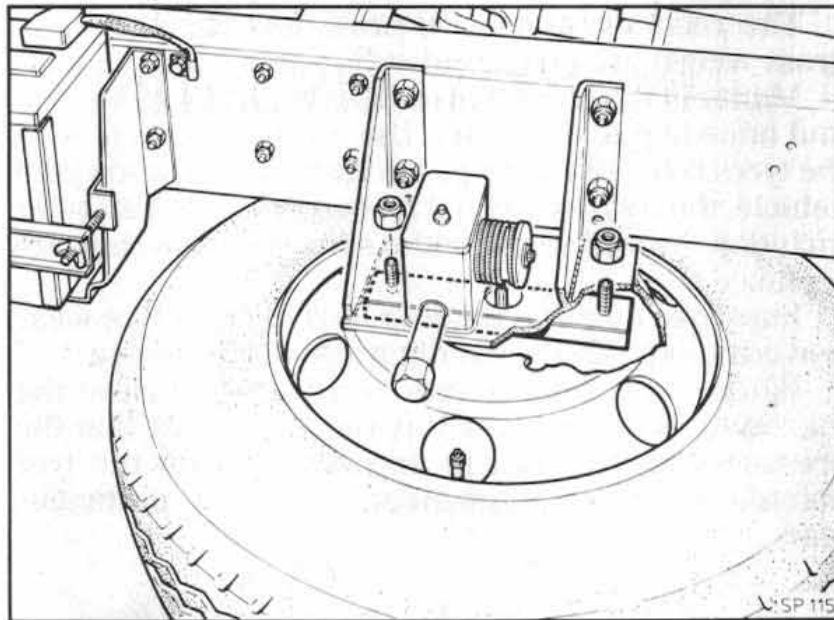

Truck Model

Spare Wheel - Van Model

To release the spare wheel remove the large nuts (A) illustrated and allow the carrier to hinge downwards.

Note that the wheel is fitted in the carrier with its stud holes uppermost (B).

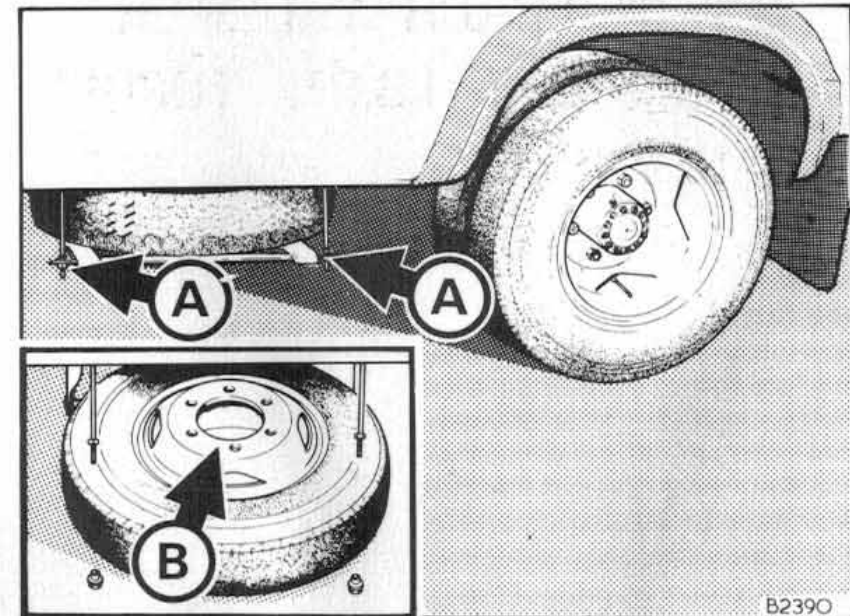

Van Model

Changing the Wheel

- 1 Apply the parking brake and, if removing a rear wheel, chock the front wheels.
- 2 Release the wheelnuts half a turn.
- 3 Raise the jack until the wheels just clear the ground. Remove the wheelnuts and wheel. Lightly oil the stud threads to prevent corrosion.

To Tighten Wheelnuts

- 1 Ensure that the mating surfaces on the nut and wheel are free of foreign matter. Failure to observe this point will mean that the nuts will not seat properly and could slacken off during service.
- 2 Fit the spare wheel.
- 3 Tighten the nuts a few turns at a time in a diagonally opposite sequence ensuring that the wheel sets squarely and evenly on the hub.

TYRES

It is advisable to run-in new tyres: this is of course taken care of when the vehicle is new and the normal running-in precautions are taken. When tyres are eventually renewed however, they should be run in at a moderate road speed for at least 150 km (100 miles) before driving at higher speeds.

It is recommended that when replacing tyres, those of a similar specification be used. Fitting tyres of a different size will not only affect the accuracy of speedometer or tachograph readings but could also affect the plated weight. Either cross-ply or radial-ply tyres on all wheels is the correct combination. Under no circumstances may cross-ply and radial-ply tyres be mixed on a vehicle.

Inflation Pressures

The recommended tyre pressures for maximum gross weight are given under 'Specifications'.

Maintain the correct pressures by checking weekly and adjusting if necessary. Use a reliable gauge with the tyres cold – if readings are taken after running the vehicle, the figures will not be correct. Check all tyres included the spare, and make sure the valve caps are replaced.

Improper inflation (high or low) hastens tyre wear and adversely affects handling and performance.

Where vehicles operate consistently below the maximum gross weights it is recommended that the pressures be reduced in accordance with the tyre manufacturers recommendations for a particular load.

WINDSCREEN WIPERS AND WASHERS

Windscreen Wash/Wipe Switch

The combined washer and wiper switch control is located on the right hand side of the steering column cowl. The switch functions only when the ignition or auxiliaries are switched 'ON'.

Wiper Operation

- 1 Intermittent wipe
- 2 Wash and wipe
- 3 Normal wipe
- 4 Fast wipe

The washers can be operated in any wipe position.

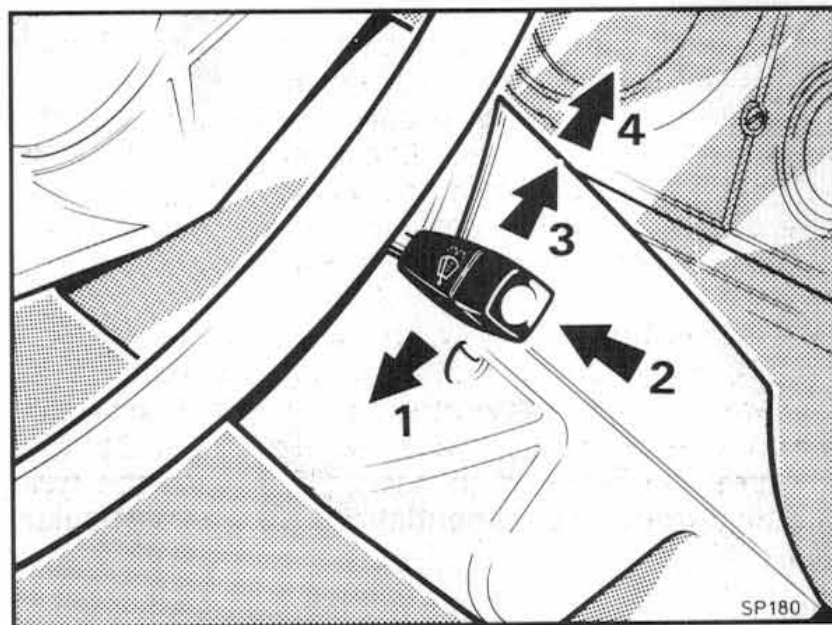

Windscreen wash/wipe switch

Wipers

The windscreen wiper blades should be renewed annually or as soon as it becomes apparent that they are not working efficiently. Genuine replacements can be obtained from your Dealer.

The drivers' wiper arm assembly is of a pantograph construction and gives a greater screen swept area on this side.

Although both wiper arms are hinged to allow them to be lifted clear of the glass when it becomes necessary to clean the screen, the driver's arm does not lock in this position. Do not pull wipers across the screen as this may damage the mechanism.

Washer jets (A) are located at the outer extremity of each arm, the supply tube being taped beneath the arm.

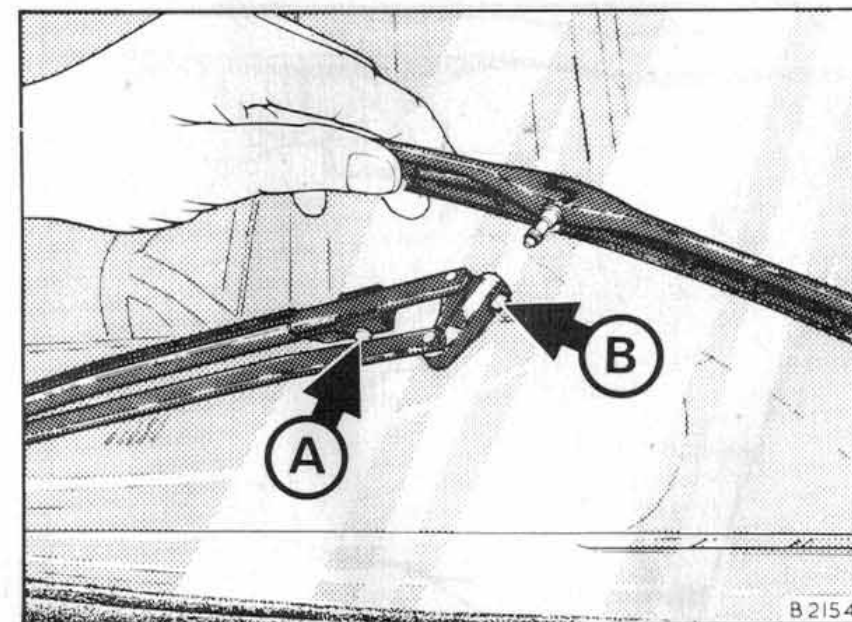

A - Jet B - Arm release catch

Arc of wipe or position of park may be altered slightly by repositioning the arm assembly on the serrated taper of the drive spindle. Care must be taken not to dislodge the washer jet tube if this is done.

To Fit a New Wiper Blade

Lift the blade and carrier away from the screen.

Depress the catch (B) to release the blade carrier and withdraw from the arm.

Renew the blade or blade and carrier assembly.

Washer Reservoir

The reservoir is situated just behind the radiator.

Brake Anti-Freeze Equipment (when fitted)

The brake anti-freeze equipment – or alcohol evaporator, fitted under the bonnet on the left hand side, permits vaporized alcohol to circulate in the air system to safeguard against the possibility of condensate freezing within the system.

During freezing conditions the level of the fluid should be checked daily and replenished if necessary with methyl alcohol.

To replenish the container unscrew the filler plug in the top of the container and fill the evaporator until it is two-thirds full.

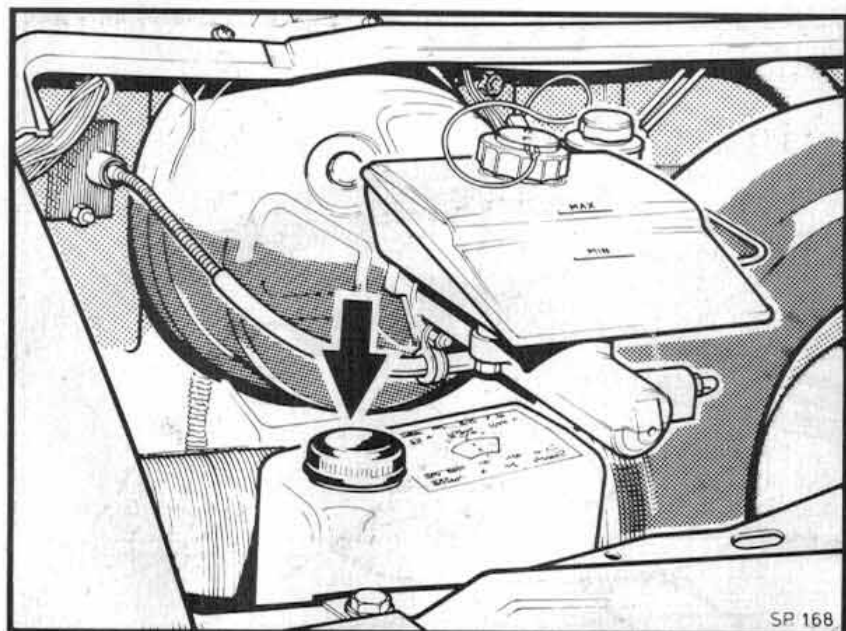

Washer reservoir

SWITCHES

Side and Headlamp Switch (A)

This switch is located on the left hand side of the steering column and has three positions.

Off. Switch up.

- * Side, (front and rear) lights on.
Side lights and headlamps on.

Instruments are illuminated when the side and tail lamps are switched 'ON'.

For main and dipping beam, see 'Combination Switch'.

*Dim Dip

This vehicle conforms to Dim Dip regulations. With side lights only switched on:-

If the ignition/starter switch is 'OFF' the side/tail lights are on as normal.

If the ignition/starter switch is 'ON' the side/tail lights are on, in addition a relay is energised which operates the dipped headlamp beam through a resistor to produce a lower intensity.

In the headlamp position, main and dipped beams operate normally.

Lights on warning

A warning device operates if the lights are on and the doors are opened.

Dip/Flasher/Horn/Direction Indicator Combination Switch

The combination switch control is located on the left hand side of the steering column cowl. Movement of the stalk controls the following:-

- 1 Left hand and right hand direction indicators.
- 2 Headlamp flasher.
- 3 Horn operation.
- 4 Headlamp main beam.

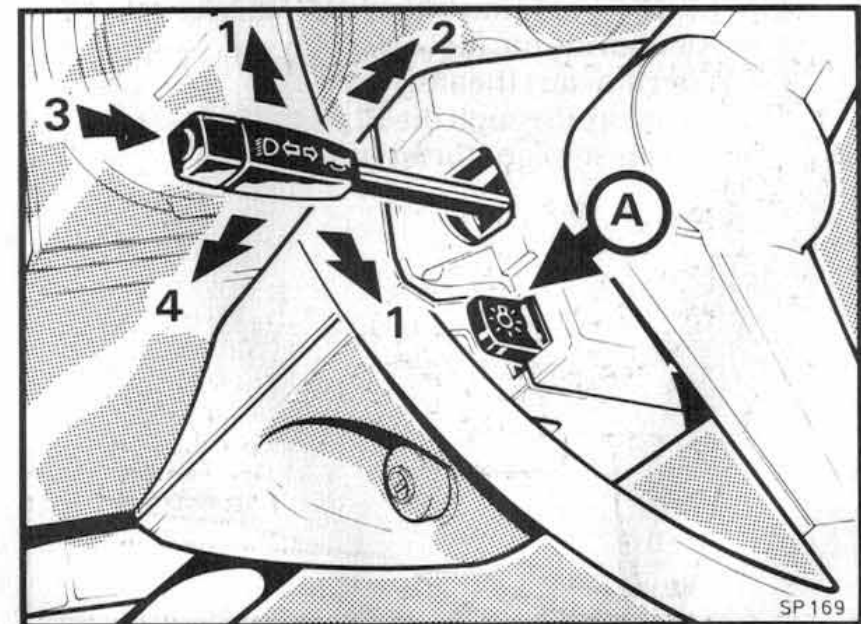

Lights and combination switch

Ignition/Steering Lock (Petrol Models)

The ignition switch also incorporates the steering column lock. The key can only be removed in position '0'.

The face of the switch is marked as follows:—

- 0 = Steering column locked – Ignition off
- I = Steering column unlocked – Ignition off
- II = Ignition on
- III = Starter motor engaged

Starter/Steering Lock (Diesel Models)

The starter switch also incorporates the steering column lock and a fuel cut-off switch. The key can only be removed in position '0'.

The face of the switch is marked as follows:—

- 0 = Steering column locked – auxiliaries off, fuel off
 - I = Steering column unlocked – auxiliaries off
 - II = Auxiliaries on, fuel on
 - III = Thermostart (heater) on
- Turn key through the III position against its stop to engage starter motor.

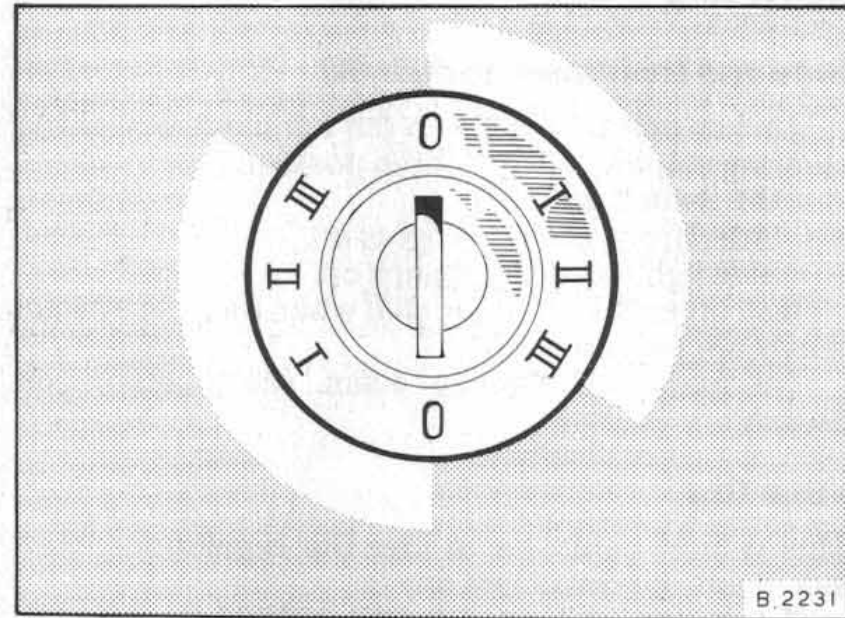

B. 2231

Ignition/starter switch

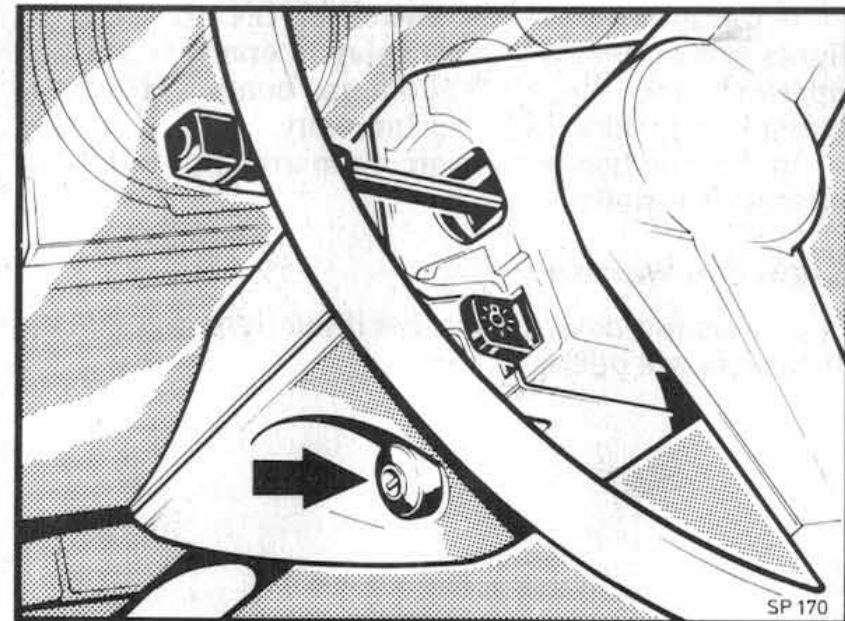

SP 170

Switch location

Warning Light Checks

Before starting ensure that the vehicle is in neutral and the handbrake is applied. With the cab door open, check that the brake fluid level warning light is on. The light should go out when the door is closed.

Turn the starter key to position II and check that the 'no charge', oil pressure and low vacuum/air warning lights are illuminated.

Temporarily release the handbrake when the low vacuum/air warning light should extinguish. If it does not, refer to the vacuum/air gauge reading, and to paragraphs given under "Brake Warning Light".

Petrol Model

Starting from cold (Automatic Choke)

Switch on the ignition and depress the accelerator pedal once, all the way to the floor and release it.

Operate the starter motor (through position III). As soon as the engine starts, the oil warning and 'no charge' warning lights must go out.

Once the engine has been operating for about 30 seconds depress the accelerator pedal briefly to allow the choke to return to the fast idle position.

If, when cold, lukewarm or warm, the engine does not start at the first attempt, depress the accelerator pedal to the floor and keep it in this position whilst operating the starter.

Diesel Models

Starting from cold

With the throttle fully depressed turn the starter key to the heater position (III) and hold for 15-20 seconds. Turn the key through the III position against the spring pressure to engage the starter motor. Release the key as soon as the engine starts and ease the throttle.

If the engine does not start within 15 seconds return the key to the heater position for a further 10 seconds and try again. Should the engine fire but not run repeat the operation for a third time.

Starting from warm

To start a warm engine it should not be necessary to use the heater. With the throttle fully depressed turn the starter key clockwise to its fullest extent.

Release the key as soon as the engine starts and ease the throttle.

If the engine fails to start ensure that the starter has stopped revolving before trying again.

STOPPING THE ENGINE

1. Remove your foot from the accelerator pedal.
 2. Switch starter/ignition switch to the 'OFF' position.
- NOTE. When stopping T/charged engines always allow the engine speed to return to idle before stopping it. Never stop the engine immediately from full throttle.**

Handbrake (vacuum/hydraulic models)

The handbrake is situated at the side of the drivers seat adjacent to the gear lever. It operates on the rear wheels and is completely independent of the hydraulic system.

Apply the brake firmly but, do not snatch or wrench the lever as this will strain the linkage and make it difficult to release.

When releasing the brake, lift the lever slightly to ease the pressure of the pawl in the ratchet, press the pawl release button on the end of the lever and then move the lever fully downwards.

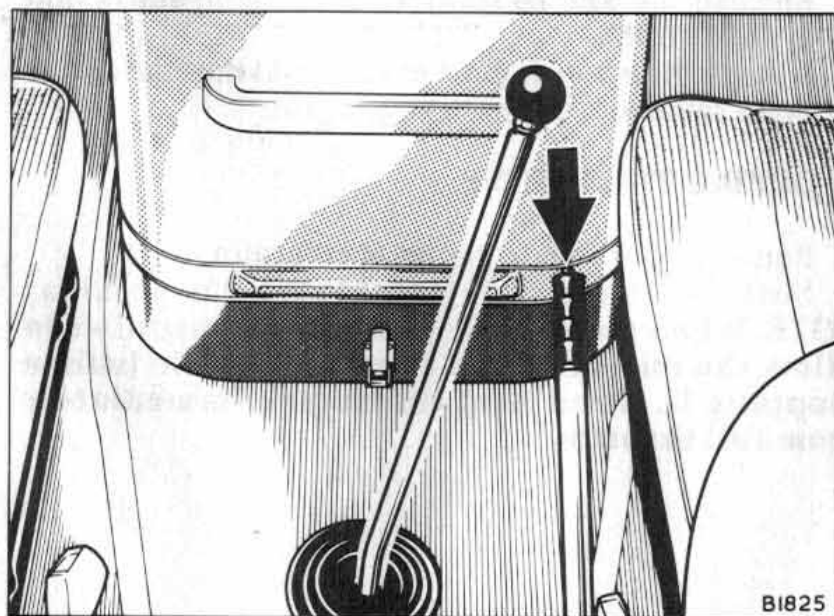

Handbrake

B1825

Parking Brake (air/hydraulic models)

The parking brake on the air hydraulic models operates on the rear wheels only.

To engage the parking brake pull the handle up making sure that it locks in the 'on' position. To release, lift the locking device out of engagement and then lower the lever to the 'off' position.

WARNING

Parking Brake Application

Except in cases of extreme emergency, only apply the parking brake after the vehicle has been brought to rest.

**FAILURE TO OBSERVE THIS INSTRUCTION
COULD RESULT IN HANDBRAKE FAILURE.**



Parking brake

B 2522

Gearchange Lever

The gear positions are as illustrated below. Always move off from rest in first gear and then smoothly through each successive gear. Select the next highest gear as soon as road speed is suitable.

When selecting first or reverse on the five speed unit it is necessary to overcome the bias spring pressure acting on the gear lever.

Remember that fuel economy can be improved by sensible use of the gearbox.

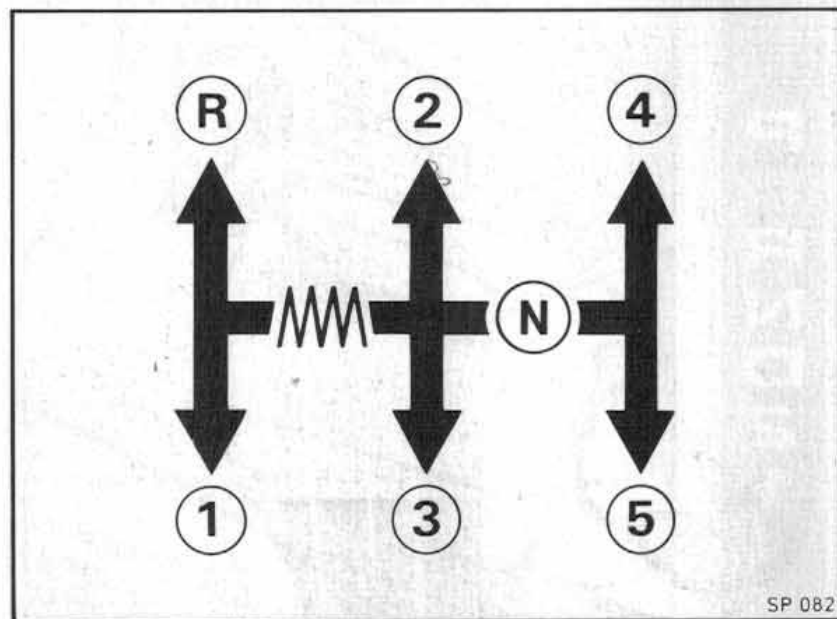

SP 082

Manual gear change

Running in

Maximum load can be applied to the diesel engines from new as soon as the oil reaches operating temperature. The petrol engine requires the usual running in procedures. However, remember that other major units, gearbox, rear axle and tyres and brakes require care during the first 500 to 1000 miles in order to reach full potential.

WARNING

Brake Warning Light and Buzzer

Under no circumstances should the vehicle be driven with either the warning light on or the buzzer sounding.

If the warning devices should operate whilst driving the vehicle, it should be brought to a halt as soon as safety permits.

AUTOMATIC TRANSMISSION

The automatic transmission greatly simplifies driving since all gear changes are made automatically. This eliminates the need for a clutch and a gearshift lever.

Automatic gearchanges are made at speeds which are relative to road speed and throttle opening. Forced throttle and Kickdown techniques provide the driver with a degree of gear control and, in addition, he may also control his gearchanging by use of the gear selector lever.

All these techniques are described in the following pages.

Selector positions

1 – Automatic Drive

This position is normally intended to be selected from rest when the vehicle is travelling on rough ground, descending or ascending steep hills.

With the transmission in top gear moving the selector lever from 'D' to '1' will initially cause a downshift to second gear, followed automatically by a downshift to first gear as the vehicle speed is reduced. Upchanges will not occur until gear lever is moved into 2 or D.

2 – Automatic Drive

This selector position is intended for use on long down grades to provide additional engine braking. Moving the selector lever from 'D' to '2' with the transmission in top gear will cause an immediate downchange to second gear. If the speed drops sufficiently the downchange will go into first gear.

D – Automatic Drive

This selector position is used for all normal driving conditions. The transmission starts off in first gear and automatically changes up at given road speeds or according to the position of the throttle pedal.

N – Neutral

With the selector in 'N', no power is transmitted to the rear wheels.

R – Reverse

This position must only be selected with the vehicle stationary, engine idling and brake applied.

P – Park

This position, as well as providing a neutral, also locks the transmission so that the rear wheels cannot turn, e.g. when parking on a steep gradient. 'P' must only be selected when the vehicle is stationary.

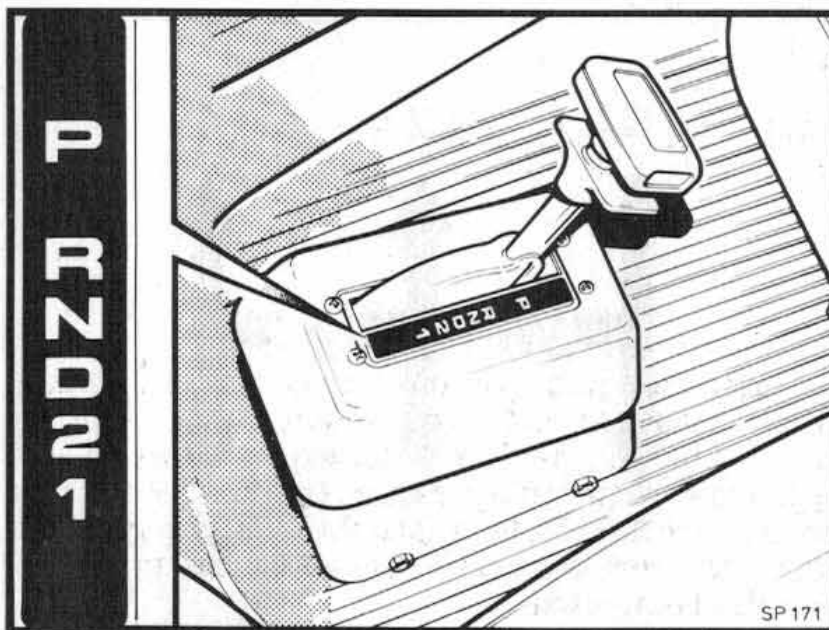

Auto. transmission selector

SP 171

IMPORTANT NOTES

1. The engine can only be started with P or N selected.
2. Before selecting the reverse or forward drive ensure the brakes are applied.
3. The vehicle will 'creep' when a drive gear is selected and the brakes are released.
4. Do not select R or P whilst the vehicle is moving.
5. Always select P when working on the vehicle with the engine running.
6. When in D avoid selecting 2 if road speed is greater than the maximum upshift speed to third gear. This will prevent over speeding the engine.
7. See "Towing".

Driving

Selector lever operation
lift the collar from:
P to R, D to 2, 2 to 1
and
N to R, R to P.

NOTE: A higher lift is required
between P and R, R and P.

Starting

With the brakes applied and the selector in N or P start the engine as previously described.

Apply the footbrake and release the handbrake. When ready to move off release the footbrake allowing the vehicle to move forward at the same time applying slight throttle pressure. Up-changes will now occur automatically but remember that the speeds at which the changes occur depend on the amount of throttles being used.

Hill Starting

This is similar to the method described above except that the footbrake is applied with the left foot whilst accelerating slightly with the right foot to prevent any backward movement.

Forced Throttle

Forced throttle is achieved by depressing the accelerator down through its hard spot. In this position, and starting from rest, gear changes will not occur until maximum road speed for each gear is reached, i.e. maximum acceleration.

Throttle Controlled Change Down

'Kickdown' is another expression used for this technique.

By pressing the accelerator sharply to its stop (hence 'Kickdown'), and provided that road speed is less than the next lowest gear maximum, an immediate change down will occur. If road speed is low enough when the kickdown is made it is possible that a change down to first gear may occur.

Manually Controlled Changes

Full up-change control is available should it be desired by moving the selector lever progressively through the selector gate to the 1, 2 and D positions. However, when employing the same method of changing down (D, 2, 1), ensure that the road speed is within the range of the lower gear before making the change thus preventing unnecessary stress on the transmission or overspeeding the engine.

Emergency Starting

It is not possible to tow or push start a vehicle fitted with this type of automatic transmission.

Towing

Transmission Inoperative

Tow the vehicle with a rear end pickup or disconnect the propellor shaft.

Transmission Operating Correctly

The vehicle may be towed for short distances in N (neutral) with rear wheels on the ground at a speed not to exceed 48 kph (30 mph). If the vehicle is to be towed for extended distances, it must be done with a rear end pickup or the propellor shaft disconnected, because the transmission receives lubrication only when the engine is running.

warranty inspection - servicing schedules - lubrication

Servicing is the best guarantee of reliability

The inspection and servicing intervals are given as a guide and are intended for vehicles operating under normal road conditions. The more severe the operating conditions, the shorter the service and inspection intervals. In some cases it will be necessary to consider servicing and inspection intervals in terms of hours rather than mileage. The Manufacturer cannot be held responsible for damage caused by driving errors, or failure to comply with the recommendations made in this handbook, particularly regarding the use of lubricants that do not conform to the specifications given.

Warranty inspection after 2500 km

This is an overall check on your vehicle. No charge is made but it is obligatory and affects the validity of the vehicle warranty. To have this inspection carried out, consult your dealer and show him the warranty card you received with the vehicle.

Lubrication

The manufacturer specifies the performance levels of the lubricants required for the correct operation of the vehicles he has built, and also sets the lubrication intervals.

These recommendations must be strictly followed.

Their observance will increase the service life of the components. Failure to comply can invalidate the warranty offered.

The lubrication table and chart set out these requirements.

● Important

Draining the oils: always drain the oils on level ground with the oils hot to aid the flow. When refitting the drain plugs, fit new sealing washers.

Checking the oil levels

(all units).

The oil levels must always be checked on level ground under the same conditions (vehicle empty or laden) and at least 5 minutes after the vehicle has stopped.

Road tests

After the warranty inspection, the selling dealer should make sure that the user clearly understands all the driving and servicing instructions in the handbook.

Cab protection

During assembly our cabs receive a special anti-corrosion treatment. An injection process is used which penetrates all the box sections of the cab. To extend the life of this initial protection, we strongly recommend that this treatment should be repeated annually. All you have to do is to contact your dealer who has the necessary equipment and material available to carry out this treatment.

RECOMMENDED SAFETY OPERATIONS

In the interest of safety it is strongly recommended that the following operations be carried out at the intervals specified, time or mileage basis whichever occurs the soonest.

30,000 km (18,000 miles) or 18 months

Change brake hydraulic fluid. All models.

60,000 km (36,000 miles) or 3 years

Serviceable hydraulic brake assemblies should be replaced or overhauled. All flexible rubber hoses must be renewed.

120,000 km (72,000 miles) or 4 years

Renew load sensing valve assembly.

"USED" Engine Oils

WARNING - Prolonged and repeated contact may cause serious skin disorders, including dermatitis and cancer.

Avoid excessive contact, wash thoroughly after contact. Keep out of reach of children.

PROTECT THE ENVIRONMENT - It is illegal to pollute drains, water courses or soil. Use authorised facilities for disposal. If in doubt, contact your Local Authority for advice."

ALL 50 SERIES MINIBUSES — STEERING COLUMN UNIVERSAL JOINT.

160,000 km (100,000 miles).

Check flexible disc for damage.

Check universal joints for wear and corrosion.

Check all splines for condition and wear.

240,000 km (150,000 miles).

Renew universal coupling.

warranty inspection - servicing schedules - lubrication

SEQUENCE OF SERVICE

OPERATOR CHECKS

Daily

Check/top-up engine oil level
Check/top-up coolant level - including anti-freeze
Check vacuum/air gauge reading
Check operation of service and parking brakes
Check operation of warning lights, road lights, horn and windscreen wash/wipe
Check/top-up brake antifreeze unit (winter only)

Weekly

Check/top-up clutch and brake fluid reservoir
Check/top-up washer bottle
Check/adjust tyre pressures
Check operation of air reservoir automatic drain valve
Inspect water and dirt trap
Inspect all units for leaks

FIRST SERVICE

2000km (1500 miles) (60 hours)

Service	kilometres (miles)	Hours
A	10,000 (6,000)	250
B	20,000 (12,000)	500
A	30,000 (18,000)	750
C	40,000 (24,000)	1,000
A	50,000 (30,000)	1,250
D	60,000 (36,000)	1,500
A	70,000 (42,000)	1,750
C	80,000 (48,000)	2,000
A	90,000 (54,000)	2,250
B	100,000 (60,000)	2,500
A	110,000 (66,000)	2,750
E	120,000 (72,000)	3,000

Note. In addition to the above servicing it is essential that engine oil and filter are changed at intermediate intervals of 5,000 km (3,000 miles) on engines which are engaged in arduous and dirty conditions, in extreme climates, low gear operation with low mileage, static operation, or frequent stop/start work.

SERVICE SCHEDULES

Operation	Services					
	First	A	B	C	D	E
Diesel Engines						
Check unit for oil and fuel leaks	X	X	X	X	X	X
Change engine oil and filter	X	-	X	X	X	X
Check/adjust valve clearances (every 48,000 miles)	-	-	-	-	-	-
Check/adjust drive belt tensions	X	-	X	X	X	X
Check/adjust slow running	X	-	X	X	X	X
Clean water trap (drain fuel tank sediment if necessary)	-	-	X	X	X	X
Clean fuel lift pump	-	-	X	X	-	X
Check fuel lines for corrosion or chafing etc.	X	-	X	X	X	X
Renew fuel filter element	-	-	X	X	X	X
Clean air cleaner element	-	-	X	X	-	-
Renew air cleaner element (every third cleaning)	-	-	-	-	X	X
Clean/reset injectors (every 60,000 miles)	-	-	-	-	-	-
Check/adjust governed speed	-	-	-	-	X	X
Check security and condition of air trunking	X	-	X	X	X	X
Check engine operation (road test)	X	-	X	X	X	X
Petrol Engine						
Check engine for oil and fuel leaks	X	X	X	X	X	X
Change engine oil	X	X	X	X	X	X
Change oil filter element (*arduous conditions)	-	*	X	X	X	X
Check/adjust drive belt tensions	X	-	X	X	X	X
Clean, regap or renew spark plugs	-	X	X	X	X	X
Check P.C.V. valve operation	-	-	X	-	X	-
Renew P.C.V. valve	-	-	-	X	-	X
Change in-line fuel filter	-	-	-	X	-	X
Clean rocker cover breather	-	-	-	X	-	X
Clean air cleaner element	-	-	X	X	-	-
Renew air cleaner element	-	-	-	-	X	X
Check fuel lines for corrosion or chafing etc.	X	-	X	-	X	-

warranty inspection - servicing schedules - lubrication

Operation	Services					
	First	A	B	C	D	E
Petrol Engine (continued)						
Check security and condition of air trunking	X	-	X	X	X	X
Clean and examine H.T. leads	-	-	X	X	X	X
Check/adjust carburettor settings	-	-	X	X	X	X
Check/adjust ignition timing	-	-	X	X	X	X
Adjust slow running	X	-	X	X	X	X
Check engine operation (road test)	X	-	X	X	X	X
Cooling System						
Check/top-up (including antifreeze)	X	-	X	X	X	X
Check system for leaks	X	-	X	X	X	X
Check condition of hoses	-	-	X	X	X	X
Clutch System						
Check/top-up fluid level	X	-	X	X	X	X
Check system for leaks	X	-	X	X	X	X
Check condition of pipes	X	-	X	X	X	X
Check operation (road test)	X	-	X	X	X	X
Gearbox						
Check unit for oil leaks	X	X	X	X	X	X
Check/top-up oil level	-	-	X	-	X	-
Change oil (or at least annually)	X	-	-	X	-	X
Clean breather	-	-	X	X	X	X
Check operation (road test)	X	-	X	X	X	X
Automatic Transmission						
Check/top-up fluid level (after road test)	X	-	-	-	-	-
Drain and refill	-	-	X	X	X	X
Renew filter	-	-	X	X	X	X
Adjust bands	-	-	X	X	X	X
Check shift speeds (road test)	X	-	X	X	X	X
Check unit for leaks	X	X	X	X	X	X

warranty inspection - servicing schedules - lubrication

Operation	Services					
	First	A	B	C	D	E
Rear Axle						
Check unit for oil leaks	X	X	X	X	X	X
Check/top-up oil level	-	-	X	X	X	-
Change oil	X	-	-	-	-	X
Clean axle breather	-	-	X	X	X	X
Check/adjust hub end float	-	-	X	X	X	-
Clean and repack hubs	-	-	-	-	-	X
Front Axle						
Check/adjust hub end float	-	-	X	X	X	-
Clean and repack hubs	-	-	-	-	-	X
Suspension						
Check 'U' bolt tightness	X	-	-	-	-	-
Check hydraulic dampers for leaks	-	-	X	X	X	X
Steering						
Check unit/system for leaks	X	-	X	X	X	X
Check/top-up oil level - manual unit	X	-	X	X	X	X
Check/top-up power steering reservoir	X	-	X	X	X	X
Change power steering reservoir filter	-	-	-	-	-	X
Lubricate swivel pins	X	X	X	X	X	X
Check operation (road test)	X	-	X	X	X	X
Propshaft						
Lubricate universal joints and sliding sleeves	-	-	X	X	X	X
Wheels and Tyres						
Check/adjust tyre pressure (including spare wheel)	X	-	X	X	X	X
Check condition of tyres	X	-	X	X	X	X
Check wheel nuts for tightness	X	-	X	X	X	X

warranty inspection - servicing schedules - lubrication

Operation	Services					
	First	A	B	C	D	E
Brakes						
Check/top-up brake fluid level	X	X	X	X	X	X
Check lining thickness (through backplate)	-	X	-	-	-	-
Check lining condition (drums removed)	-	-	X	X	X	X
Check load sensing valve security	X	-	-	-	-	-
Check/adjust load sensing valve setting (first A service only)	X	X	-	-	-	-
Check/adjust handbrake travel	X	-	X	X	X	X
Check condition of pipes and hoses	X	-	X	X	X	X
Examine front brake pads for wear		X	X	X	X	X
Check operation of auto drain valve	X	-	X	X	X	X
Clean auto drain valve	-	-	-	-	X	X
Check/decoke compressor*	-	-	X	X	X	X
Clean in-line filters	-	-	X	X	X	X
Check system for leaks	X	-	X	X	X	X
Lubricate handbrake compensator	-	-	X	X	X	X
Check operation of brakes (road test)	X	-	X	X	X	X
Examine brake caliper slide pin rubber boot & bush	-	-	X	X	-	-
Renew caliper slide pin, rubber boot & bush	-	-	-	-	X	X
Electrical						
Check operation of all instruments	X	-	X	X	X	X
Check operation of warning lights	-	-	X	X	X	X
Check operation of horn, wipers and washers	-	-	X	X	X	X
Check operation road lamps	-	-	X	X	X	X
Check/top-up battery	-	-	X	X	X	X
Clean and protect battery terminals	-	-	X	X	X	X
Check operation of brake fluid level switch	-	-	X	X	X	X
Visually check wiring	-	-	X	X	X	X
Check security of battery	X	-	-	-	-	-
Cab						
Check operation of door locks and hinges	X	-	-	-	-	-
Lubricate door locks and hinges	-	-	X	X	X	X
Check condition and security of sound insulation panels	X	-	X	X	X	X
Check condition and security of safety belts	X	-	X	X	X	X

warranty inspection - servicing schedules - lubrication

RECOMMENDED LUBRICANTS

UNIT	AMBIENT TEMPERATURE	RECOMMENDED LUBRICANT	GRADE	SPECIFICATION
Phaser 90	All temps. down to -15°C	Elf Multi Perfo XC	15W/40	CCMC D2 MIL-L-2104C
	All temps. above 10°C	Elf Perfo XC	SAE 40	
	5°C to 35°C		SAE 30	
Phaser 110T All Operations	All temps. down to -15°C	Elf Multi Performance 3D	15W/40	CCMC D2+ MIL-L-2104D
	All temps. above 10°C	Elf Performance 3D	SAE 40	
	5°C to 35°C		SAE 30	
Phaser 90 Only All Operations	All temps. down to -15°C	Elf Multi Performance 4D	15W/40	CCMC D3 S.H.P.D.
	All temps. down to -15°C	Elf Multi Performance 2B	15W/40	CCMC D1 MIL-L-46152
	All temps. above 10°C		SAE 40	
All Operations	5°C to 35°C	Elf Performance 2B	SAE 30	

Important. Diesel engines operating on high sulphur content fuels (0.6 to 1.0%) should use MIL-L-2104C lubricating oil only.

6.225 PETROL ENGINE 6 CYL.	MULTI-GRADE	40°C to -18°C	Elf Sporti Grade		API SE/CC
			or Elf Super Sporti Grade		API SF/CC
		Below -18°C	Elf Super Sporti Grade		API SF/CC
	MONO-GRADE	27°C to 0°C	SAE 30	Elf Performance 2B OR	API SE/CC
		0°C to -12°C	SAE 20W		
		-12°C to -23°C	SAE 10W	Elf Performance 3D	API SF/CC

warranty inspection - servicing schedules - lubrication

RECOMMENDED LUBRICANTS

<i>UNIT</i>	<i>AMBIENT TEMPERATURE</i>	<i>RECOMMENDED LUBRICANT</i>	<i>SPECIFICATION</i>
GEARBOX S5-24/3	All temperatures to -15°C	Elf Perfo XC 30	MIL-L-2104C
	All temperatures to -25°C	Elf Tranself EP 80W/90	MIL-L-2105A
GEARBOX T5-290	All temperatures to -25°C	Elf Tranself, EP, 80W/90	MIL-L-2105A API GL4
STEERING BOX (Manual)			
REAR AXLE			
STEERING BOX (Power) and RESERVOIR	All	Elf Elfmatic G2	DEXRON II
AUTOMATIC GEARBOX	All	Elf Grease Multi EP2	LITHIUM SOAP BASE NLGI.2. INCORPORATING E.P. ADDITIVES
PROPSHAFTS			
WHEEL HUBS			
HAND BRAKE LINKAGE			
SWIVEL PINS	All	Elf Grease Multi MOS 2	LITHIUM SOAP BASE NLGI.2. INCORPORATING MOLYBDENUM DISULPHIDE
AUTO BOX LINKAGE	All	Lockheed Universal 329.S	Dot 3 FMVSS 116
BRAKE & CLUTCH SYSTEMS			
CLUTCH ACTUATION- CLEVIS, LEVER, BRG. CARRIER & SPLINE	All	Elf Grease Multi MOS 2	LITHIUM SOAP BASE NLGI.2. INCORPORATING MOLYBDENUM DISULPHIDE
ENGINE COOLANT CONCENTRATE. (ANTI-FREEZE)	All	ICI 007 MOBIL PERMAZONE ELF ANTI-FREEZE RTIL	BS 6580 1985

servicing

ENGINE OIL

Filler Cap (A)

Dip Stick (B)

Change oil when warm

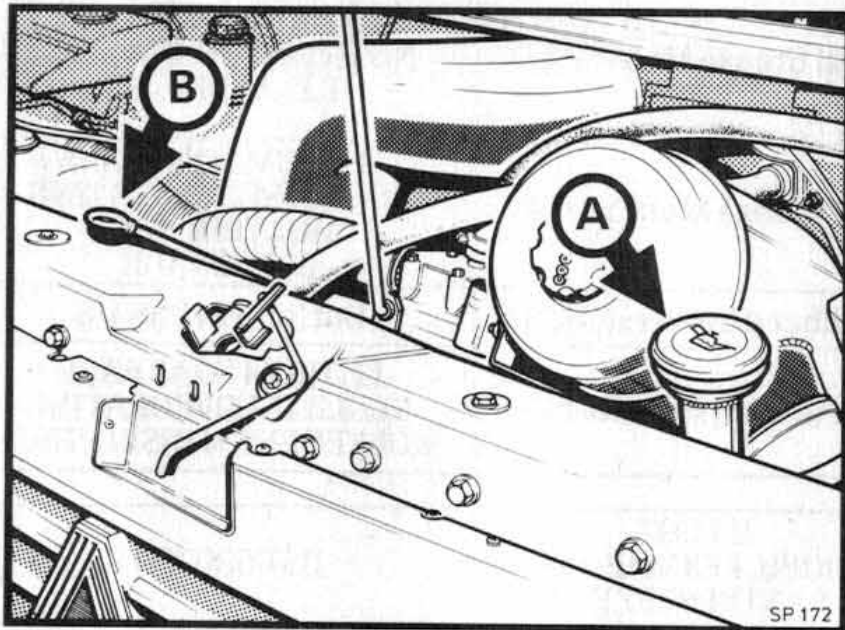

Oil Fill and Dip

OIL FILTERS

To change, unscrew cartridge. Cartridge is not re-useable. When fitting new cartridge, lightly oil the seal and tighten by hand only. Run engine and check for leaks. Re-check oil level.

OIL FILTER (A)

DRAIN PLUG (B)

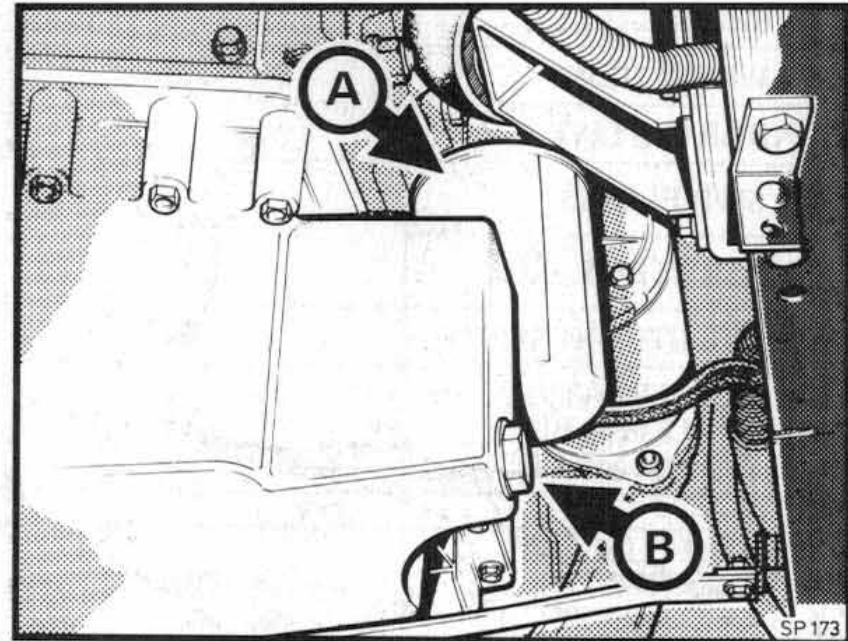

Oil filter and drain plug – diesels

AIR CLEANER (A)

Unscrew knob (A) and remove cover. Unscrew wing nut (B) and remove element. Clean or change (see service schedules). Replace correctly.

AIR RESTRICTION INDICATOR (C)

Mounted on the side of the air cleaner body. A red warning indicator remains locked up after the engine has stopped if the air intake is restricted. Clean or change filter. Reset indicator by pressing button at base of indicator.

TO CLEAN THE ELEMENT

1. Carefully tap the side of the element against the palm of the hand to remove surplus dust.
2. Blow out any loose dirt or sand with compressed air, blowing along the pleats and in the opposite direction of the normal operating air flow through the element. Pressures in excess of 7 bar (100 lbf/in²) should be avoided otherwise rupture of the pleats could occur.
3. Wipe the inside of the cleaner body with a clean damp cloth.
4. Refit the cleaned or new element and top cover.

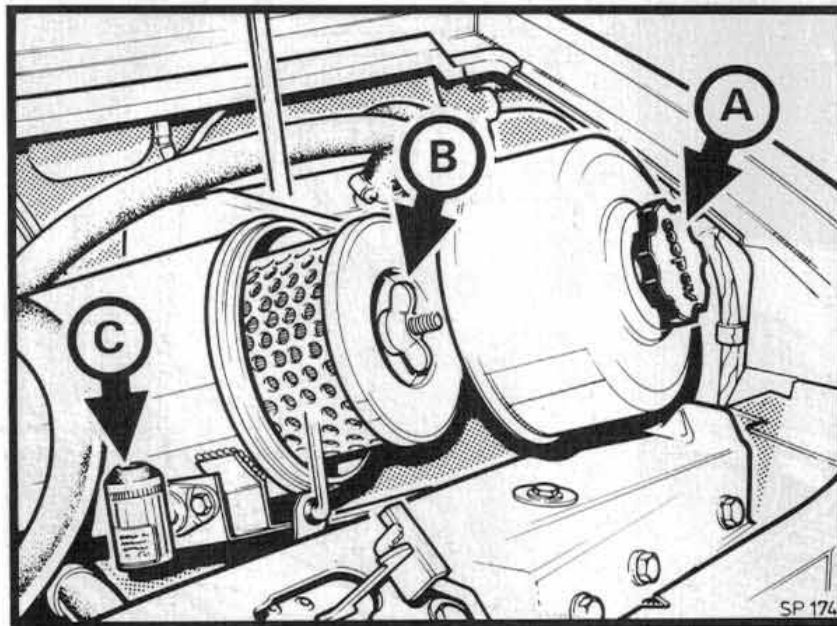

Air cleaner and restriction indicator

COOLING SYSTEM

General

The radiator header tank is situated to one side of the engine compartment beneath the bonnet.

No radiator drain plug or tap is provided.

Cylinder block drain plugs are located on the engine as follows:-

6 Cylinder petrol engine.

Right hand side immediately to rear of the oil filter.

4 Cylinder diesel engine (illustrated).

Rear right hand side near clutch release lever.

WARNING. If it is necessary to remove the pressure cap from the header tank whilst the engine is hot, cover the cap with a cloth and release it very slowly allowing a gradual escape of pressure (steam) from the system.

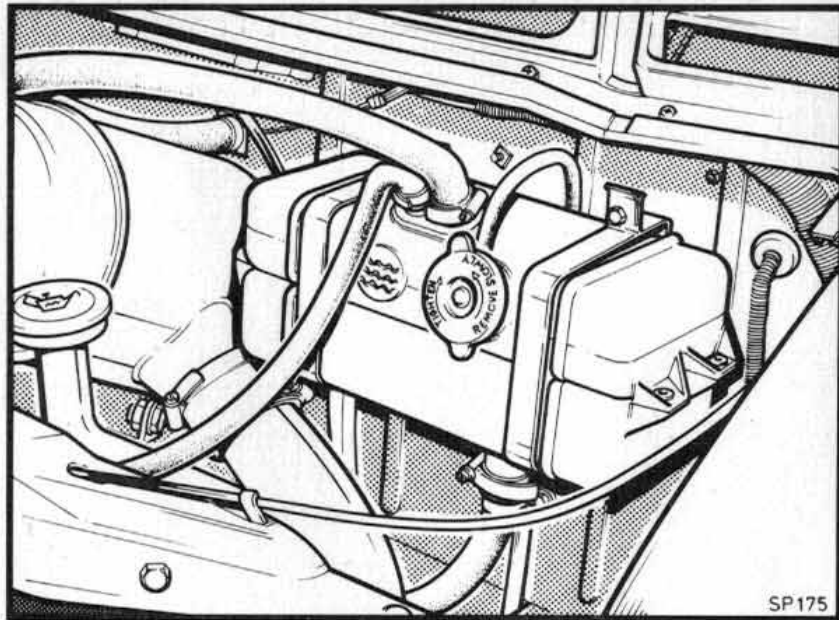

Header tank

Radiator External Cleaning

In very dusty conditions or where insects are numerous the radiator (core) should be kept clear by periodic blowing with compressed air from the engine side.

Draining the Cooling System

1. Set the heater control to 'Hot' and remove the header tank cap.
2. Remove the cylinder block drain plug and disconnect the bottom radiator hose at the radiator. Allow to drain.

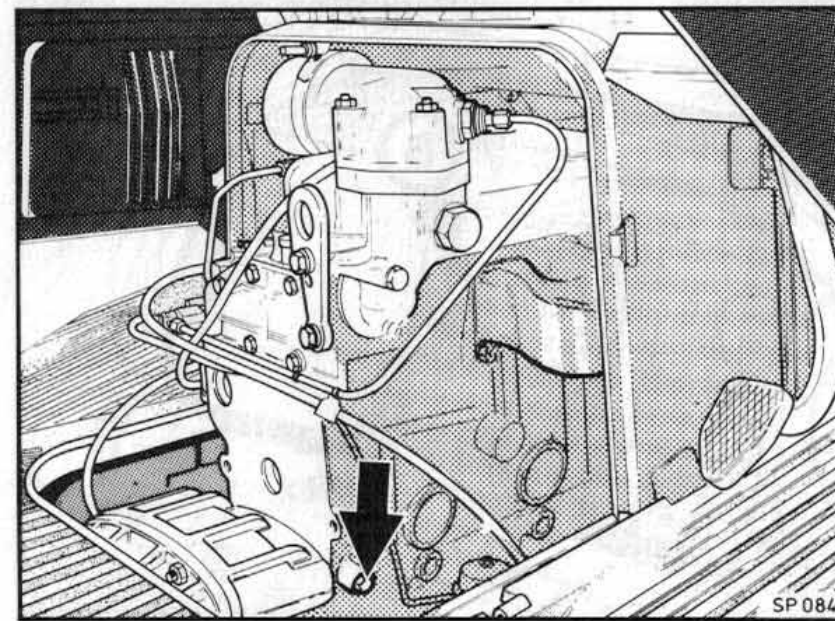

Cooling water drain plug – diesels

Flushing the Cooling System

It is recommended that the cooling system be flushed out every 2 years to remove any sediment or sludge which may affect the efficiency of the system. The best time to do this is when refilling the system with anti-freeze.

1. Drain the system as described previously.
2. Insert a cold water supply hose in the header tank filler neck, and regulate the flow of water so that overflow does not occur. Flush the system until clean water is seen to flow from the bottom hose and cylinder block.
3. Refill the system.

To Refill

1. Set the heater control to 'Hot'.
2. Refit the bottom hose and replace the cylinder block drain plug.
3. Refill the system with clean (soft where possible) water and the necessary proportion of anti-freeze.
4. Run the engine for a short time to disperse any air locks and check for leakage.
5. Re-check coolant level and top up as necessary.
6. Refit the engine under-tray if previously removed.

Protecting the system throughout the year

This vehicle is supplied with a cooling fluid which contains a proportion of 30% by volume of antifreeze. This fluid ensures protection of the cooling system (anticorrosion, scale inhibition, etc.). The proportion of 30% gives frost protection in temperatures down to -12°C .

For temperatures below this, it is essential to adopt the correct concentration for the protection required.

Above 55%, protection against cold and cooling efficiency are reduced.

Therefore, never exceed this value.

Note

The protective mixture can remain in the system for 2 years, but the concentration must be closely monitored during the winter months.

In all countries, whatever the climate or the season, never allow the concentration to drop below 30% in order to ensure adequate anti-corrosion protection of the system.

DIESEL ENGINES

Smoke Emission

To ensure that your vehicle complies with the smoke emission regulations the following points must be observed:

- 1 NEVER attempt to alter the diesel fuel injection pump and governor settings. This work is for the specialist and must only be entrusted to him.
- 2 NEVER use substitute equipment for the fuel, air or exhaust systems. Only parts to the original specifications may be used.
- 3 ALWAYS ensure that the fuel, air and exhaust systems are correctly maintained.

Remember, it is an offence for vehicles to give off excessive smoke.

Fuel Tank - Draining Sediment

At the recommended intervals the fuel tank should be drained of any sediment. The fuel tank drain plug is located at the base of the fuel tank.

Place a suitable container beneath the drain plug. Remove the plug and allow about half a pint of fuel to drain off before replacing the plug.

Water and Dirt Trap

The water and dirt should be drained from the bowl at the periods shown in the service schedule, unless fuel or operating conditions require more frequent attention.

- 1 Drain the contents of the bowl into a suitable container.
- 2 Remove four setscrews securing the bowl clamp ring to the head casting, and remove clamp ring and plastic bowl.
- 3 Thoroughly clean bowl and deflector plate.
- 4 Check the sealing ring in the head casting, renew if necessary.
- 5 Fit the deflector plate in the bowl and fill with clean fuel prior to refitting and ensure an airtight joint is obtained.
- 6 Vent the fuel system.

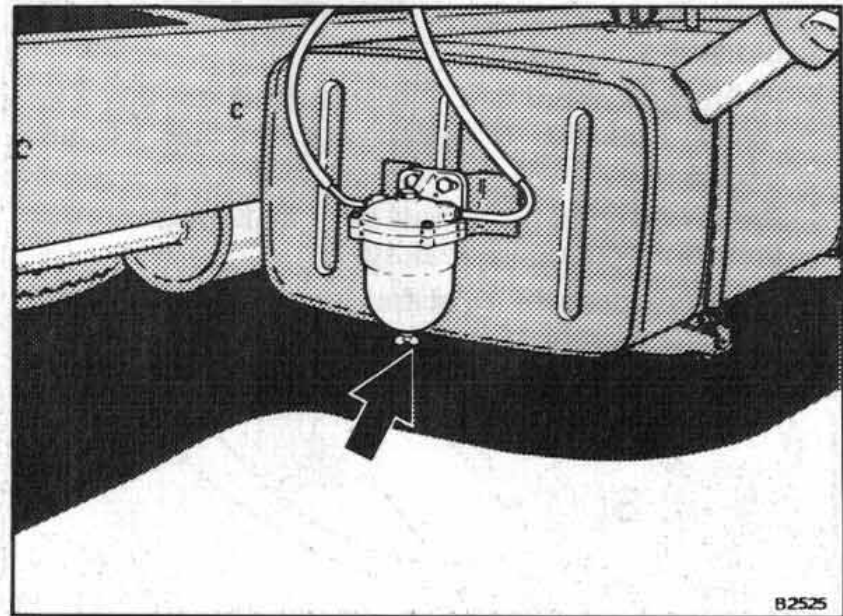

Water and dirt trap

B2525

Fuel Lift Pump

The fuel lift pump is located on the right hand side of the engine below the exhaust manifold.

To clean the gauze filter (B) release the setscrew on the domed cover and remove the cover. The gauze filter can then be lifted out and wiped clean using a lintless cloth.

Clean out the sediment chamber ensuring dirt does not enter the interior of the pump.

Ensure that the gasket (A) is in good condition and renew if necessary. Also ensure that an airtight joint is made between the domed cover and pump body.

Vent the system of air.

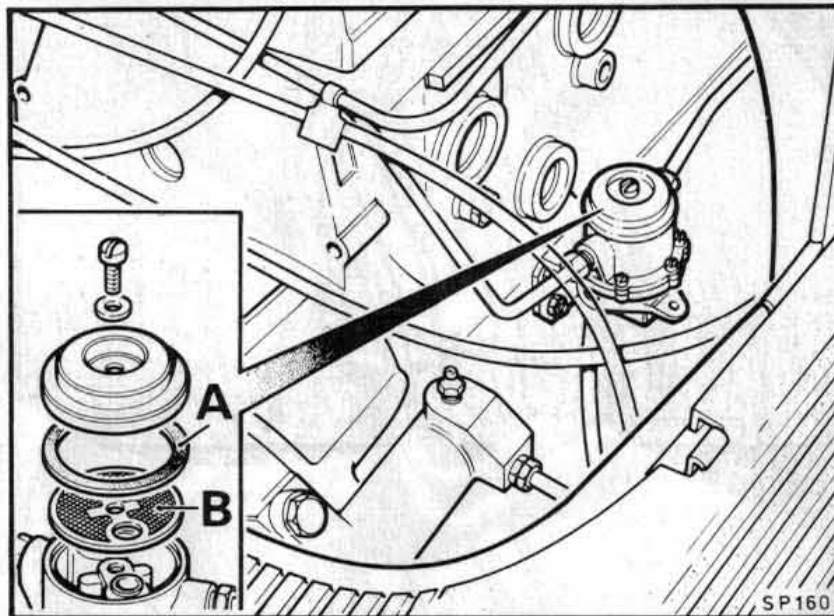

Fuel lift pump

Final Fuel Filter Element - To Renew

The filter is located to the rear of the engine. Access to the unit is made by removing the rear engine cover.

The element cannot be cleaned but should be renewed at the recommended periods.

- 1 Place a protective cover over the starter motor to protect it from any spilt fuel.
- 2 Clean the exterior of the fuel filter assembly.
- 3 Unscrew the centre bolt securing the filter bowl to the top cover.
- 4 Drop the filter bowl clear and discard the filter element.
CAUTION. Do not allow fuel to drip on to sound insulation material.
- 5 Clean the bowl with paraffin or fuel oil.
- 6 Renew the 'O' ring located in the filter head and the upper and lower sealing rings.
- 7 Place the bowl on the base of the new filter element and offer up the assembly squarely to the filter head so that the top rim of the element is centrally located against the sealing ring in the filter head.
- 8 Hold the assembly in this position and locate and tighten the securing bolt.
- 9 Prime the fuel system as described in this section.
- 10 Remove the protective cover from the starter motor.

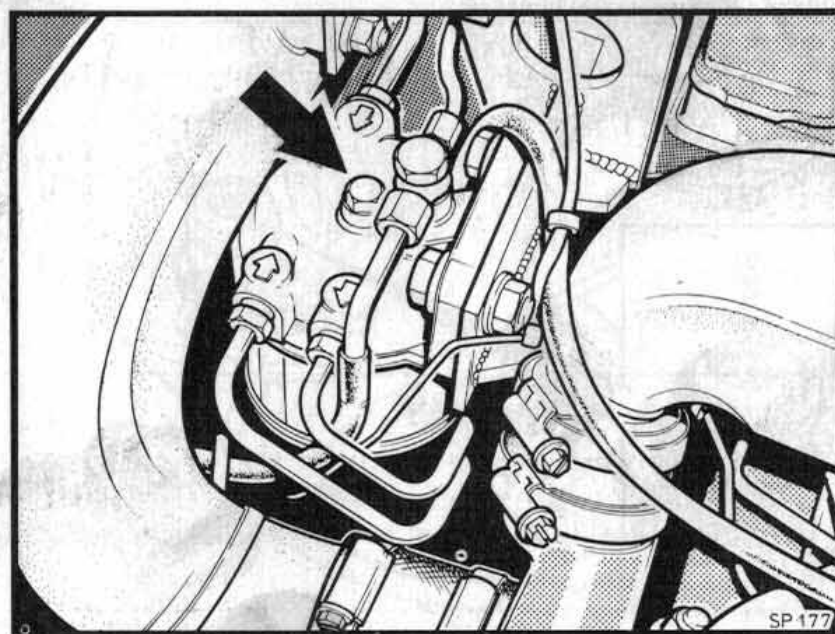

Fuel filter retaining bolt

To Vent the Fuel System

1 Although the fuel filter is self venting through a 0.5 mm diameter hole, it will be quicker to fill an empty filter by operating the fuel lift pump priming lever after first loosening the fuel return banjo bolt. When fuel free from air bubbles appears around the banjo, retighten bolt.

NOTE. It may be necessary to turn engine until priming lever is at the bottom of its stroke to obtain full movement.

2 Set throttle to fully open position. Engine stop solenoid must be fully energised by turning starter key to position "II".

3 Loosen the pipe union nut (A) at the fuel injection pump inlet. Operate priming lever until fuel free from air bubbles appears around threads, then retighten union nut.

4 Loosen any two high pressure pipe unions at the injector end.

5 Operate starter motor until fuel free from air bubbles issues from both pipes. Retighten both pipe unions.

6 Start the engine. If the engine stops after a short running period, there may still be some air in the system. Reprime the complete system.

WARNING

When carrying out this procedure great care must be taken to prevent fuel under pressure from contacting the skin since it will penetrate with ease.

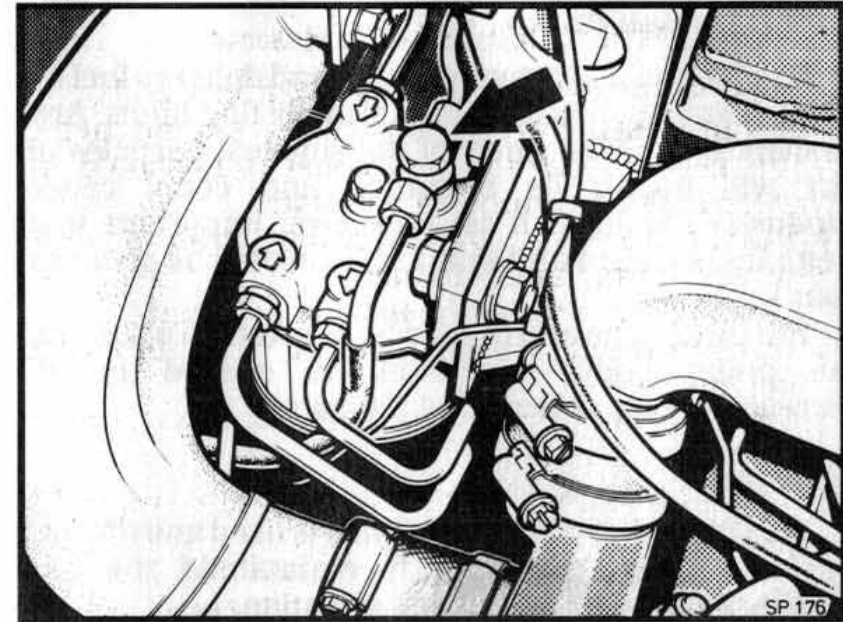

Fuel Return Banjo Connection

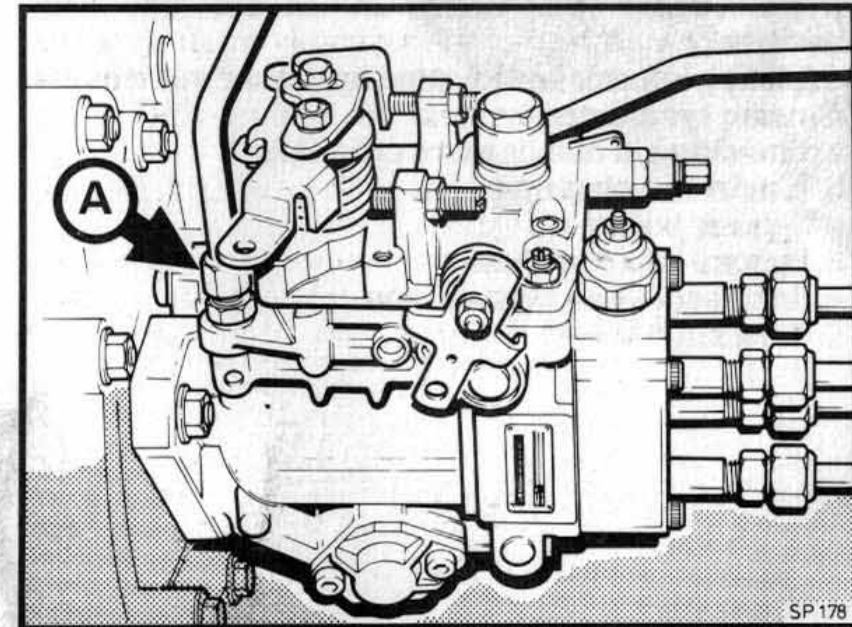

Fuel Injection Pump

Fuel Injection Pump

The fuel injection pump meters and delivers fuel oil to the injectors. It is built to extremely fine limits. Any mishandling or the entry of the smallest particles of dirt will impair its operation and could cause expensive damage. It is, therefore, important that clean fuel be used and that attention only be given by your Dealer.

The pump type and number – as given on a plate on the pump body – should be quoted in all correspondence concerning the pump.

Injectors

Providing that good-quality fuel is used and the fuel filtration system is properly maintained the fuel injectors will require minimal attention.

Cleaning and testing of injectors must only be carried out by your Dealer at the recommended intervals.

A faulty injector is indicated by one or more of the following symptoms:–

- a. Knocking in one or more cylinders
- b. Engine overheating
- c. Loss of power
- d. Smoky (black) exhaust
- e. Increased fuel consumption
- f. Misfiring.

Engine Speed Adjustment

The adjustment screw on original fuel pumps is set and sealed by the manufacturer. The setting must not be interfered with as this could affect the engine warranty.

If a new pump has been fitted, check the maximum no load speed with the engine at its normal temperature of operation. If necessary, this speed can be adjusted by the outer adjustment screw (A). The maximum no load speed is the last part of the fuel pump setting code stamped on the side of the fuel pump. A typical setting code is as follows: 2643J000/CK/1/2960; in this example the maximum no load speed is 2960 rev/min.

With the engine at the normal temperature of operation check that the idle speed is 625 rev/min. If necessary adjustment can be made by the inner adjustment screw (B).

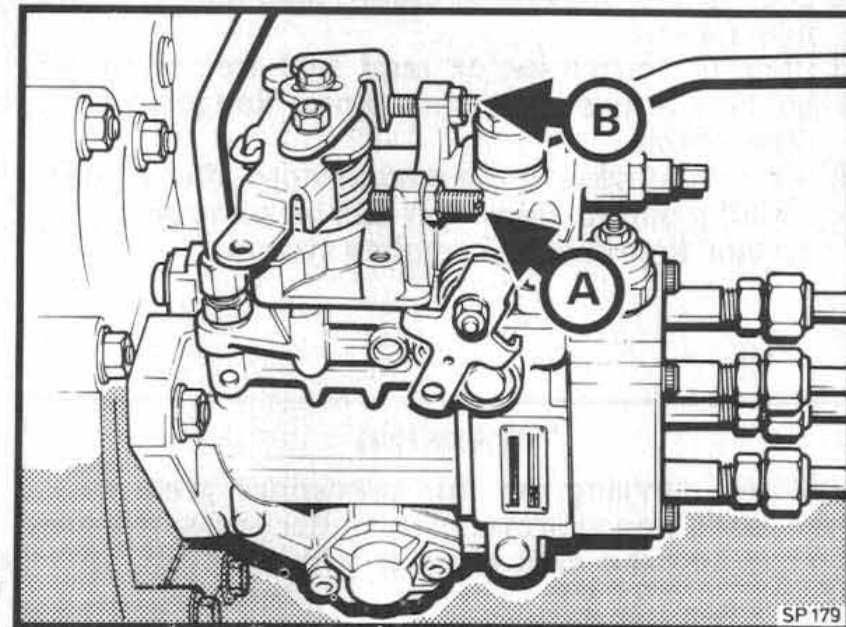

Engine Speed Adjustment

PETROL ENGINE

General

The fuel and air intake system is designed to ensure that the vehicle meets the current exhaust emission standards. It is therefore important that should it be necessary to renew any parts, only parts which conform to the original specification may be fitted.

It must also be stressed that any adjustments or settings made do not result in excessive CO emission and they should therefore be carried out by your Dealer who has the necessary emission analysing equipment.

NOTE. When fuel pipe clips are removed always ensure that they are refitted securely when the service operation is completed.

CRANKCASE VENTILATION

This system ensures that engine fumes and vapours from the crankcase are recirculated into the air intake system and therefore cannot pollute the atmosphere.

It is essential that servicing of the ventilation system be carried out as specified in the Service Schedule.

Failure to maintain these items can result in sludging of the oil and erratic slow running of the engine.

Fuel Lift Pump

The pump is located on the right hand side of the engine.

The pump is a sealed unit and no servicing is necessary except for an occasional check for security to the cylinder block and for signs of any fuel leakage.

Crankcase Inlet Air Cleaner

To Clean

- 1 Disconnect the hoses at the inlet air cleaner (A).
- 2 Pull the cleaner from the rocker cover.
- 3 Wash the cleaner thoroughly in paraffin and allow to dry.
- 4 Fill the cleaner with clean engine oil and lay it so that the oil drains off through the vent outlet at the top.
- 5 Push the cleaner into the rocker cover and reconnect the hoses.

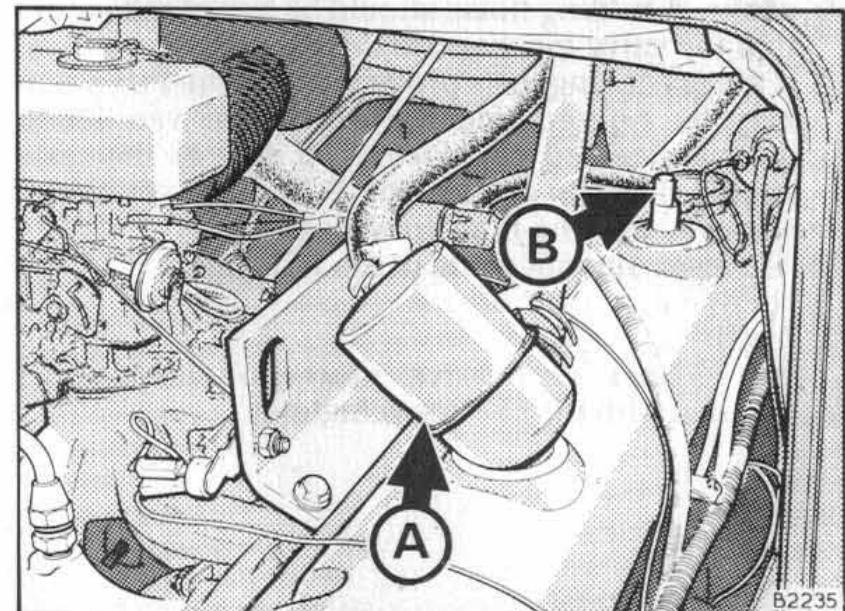

Crankcase inlet air cleaner and PVC valve

PCV Valve

To Test

Operation of the PCV valve should be checked as follows:-

- 1 With the engine idling pull the PCV valve (B) from the rocker cover. A hissing noise should be heard as air passes through the valve and a strong suction felt when a finger is placed over the valve inlet.
- 2 Replace the PCV valve in the rocker cover.
- 3 Remove the crankcase inlet filter and hold a piece of stiff paper or thin card over the hole. Allow about a minute for crankcase pressure to drop and the paper should be sucked against the hole with noticeable force.
- 4 Replace the crankcase cleaner.
- 5 Switch off the engine.
- 6 Remove the PCV valve from the rocker cover and shake. A rattling noise should be heard indicating that the valve mechanism is free.
- 7 If the preceding tests prove positive the PCV valve may be refitted and the crankcase ventilation system deemed satisfactory. If any of the tests should indicate a fault, the PCV valve should be renewed and the pipe lines cleaned.

NOTE. Never attempt to clean the PCV valve.

To Renew

The cleaner and valve must be renewed in accordance with the service schedules.

In Line - Fuel Filter

A renewable paper element type filter is mounted adjacent to the fuel tank and in the fuel line between tank and lift pump.

Caution. To prevent the siphoning effect which can occur with a full tank, disconnect the feed line at the tank unit.

To renew the element, unscrew the bottom container and pull the old element from the stub leading away from the upper chamber.

Remove the large sealing ring from the filter body and clean the container thoroughly.

Fit a new element engaging the 'O' ring seal over the upper chamber stub. Fit a new sealing ring and replace the container.

Filters should be renewed at the periods stated in the service schedules.

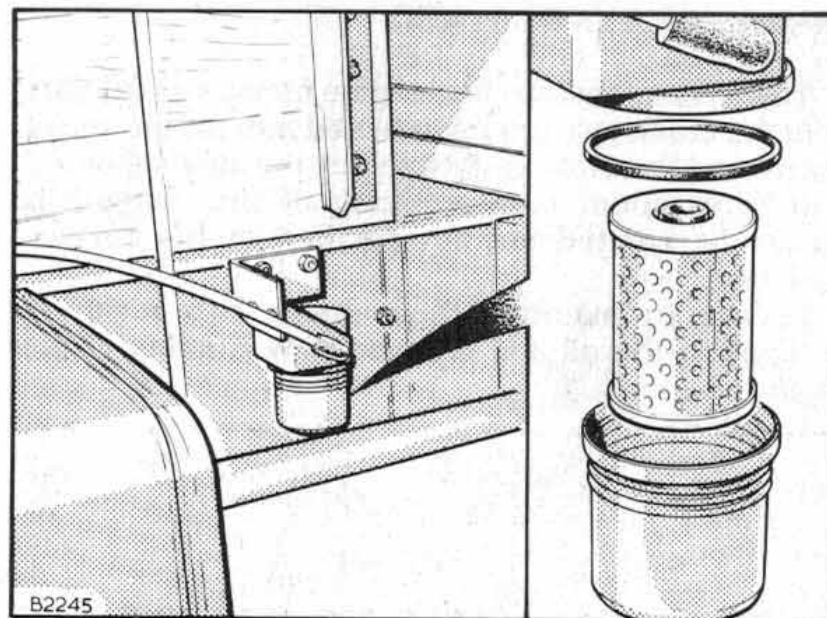

Inline Fuel Filter

Carburettor

Caution Carburettors are designed to comply with current legislative requirements in respect of emission standards. It is very important that any adjustments which can affect these emissions are left to your Dealer.

Any replacement parts which might be necessary must be identical in specification to those fitted as original equipment.

Idling Adjustment

Minor adjustments may be made only at the idling screw in order to maintain the recommended idling speed as quoted in 'Specifications'.

With the engine at its normal operating temperature, turn the idling screw clockwise to increase engine speed.

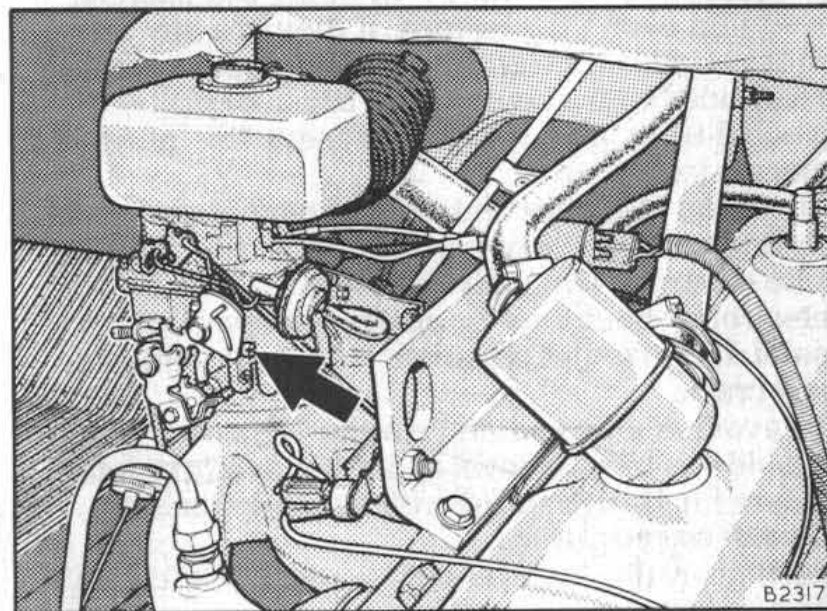

Idling Screw

B2317

WARNING

- 1 The ignition high tension circuit – between the coil and spark plugs, and the control unit – operates at very high voltage which can be dangerous, particularly to people with heart complaints or with 'pacemakers'. Do not handle these leads when the engine is running.
- 2 The control unit of the electronic ignition is mounted on the L.H.S. of the engine compartment beneath the bonnet. The circular protrusion on the top of the control unit is a power transistor that carries very high voltage. Take care not to touch the transistor when the engine is running.

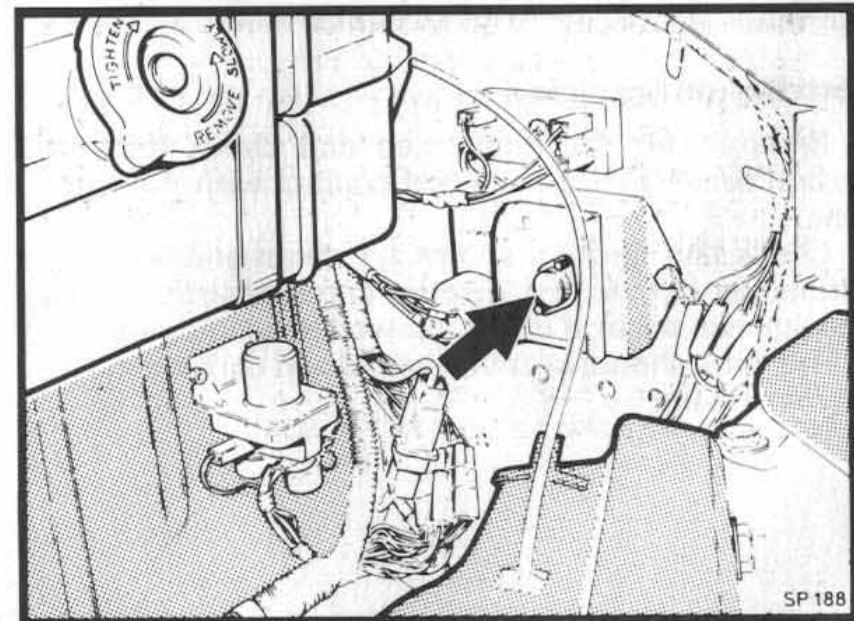

Control unit electronic ignition

SP 188

ELECTRONIC IGNITION SYSTEM

Description

The petrol engine is equipped with an electronic ignition system, the usual 'contact breaker' being replaced by an electromagnetic pick-up that requires no periodic adjustments or servicing. The position of the pick-up in relation to the moving parts of the distributor is very critical and the setting requires specialist knowledge and equipment. You are advised not to interfere with the distributor beyond the attention detailed under "Distributor Servicing" and to allow only an authorised Dealer to carry out any additional work.

The ignition coil, high tension leads, distributor and sparking plugs fitted conform to ignition suppression regulations. When replacements are necessary they must have identical performance characteristics to the original equipment.

Distributor Servicing

Remove the distributor cap and check that the carbon brush is making good contact with the rotor arm.

Check that ignition cables are clean and securely connected but do not disturb unnecessarily. Spark leakage can occur if dirt is allowed to accumulate.

Any fault should be investigated and corrected only by your Dealer.

Sparking Plugs

The sparking plugs should be removed, cleaned and adjusted at the recommended intervals. The correct gap setting and plug type will be found under "Specifications".

CAUTION

The plugs have a taper seat which provides a gas tight seal; therefore no gasket is necessary. The plugs are $\frac{5}{8}$ inches across flats and should be removed using a thin walled deep set socket, $\frac{3}{8}$ in. square drive and a universal joint.

To Remove and Clean

- 1 Disconnect the high tension leads. Do not pull on the leads to disconnect them from the plugs.
- 2 Clean the plug recesses in the cylinder head.
- 3 Remove the plugs with a well-fitting box spanner.
- 4 Examine each plug in turn. If they are oily wash them in petrol. Clean any carbon deposit on the electrodes with a copper wire brush or preferably a sand-blast type cleaner. Renew the plugs if electrodes are worn.
- 5 Check the plug gaps and adjust if necessary. When setting the gap it is important to note that only the side electrode should be bent and that the central electrode should not be used as a lever fulcrum point. If the central electrode is bent the insulation will crack.
- 6 To avoid damage when refitting, the spark plugs should be screwed down as far as possible by hand before finally tightening with a plug spanner.
Do not overtighten.
- 7 Reconnect the high tension leads in the correct firing order.

DRIVE BELTS - ADJUSTMENTS

The belt should never be allowed to become loose enough to slip as this can cause overheating and undercharging, nor should it be overtightened as this may be the cause of overload on the alternator or water pump bearings.

To Check

To check belt tension apply a light pressure to the belt at a point midway along the longest unsupported length and measure the deflection. This should be as follows:-

- 6 Cylinder petrol engine – 12mm (1/2in)
- 4 Cylinder diesel engine – 9mm (3/8in)

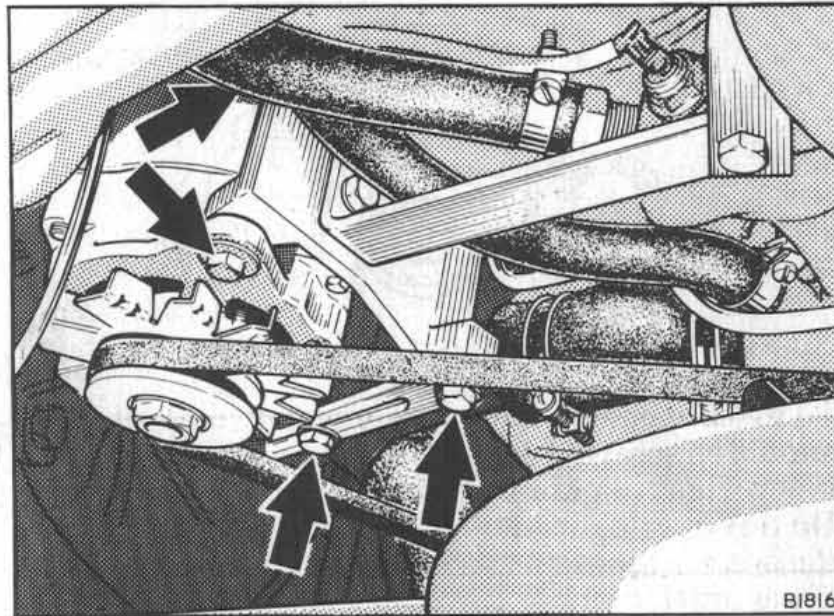

Alternator fastenings – 6 cyl. petrol

B1816

To Adjust - Fan Belt

Belt tension is adjusted by altering the position of the alternator.

Loosen the nuts and bolts securing the alternator to its mounting bracket and adjusting strap and the setscrew securing the strap at the cylinder block.

Move the alternator to give the correct tension, tighten all fixings and recheck the tension.

NOTE. When fitting a new belt, the adjustment should be rechecked after a short period of running to allow for initial stretch and bedding in.

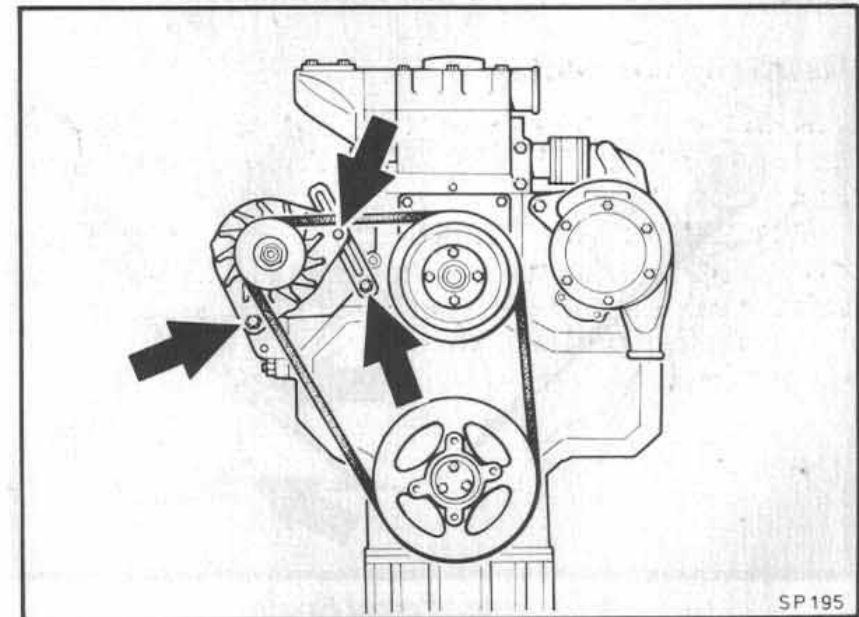

Belt adjustment – diesels

SP195

Belt Adjustment (Power Steering)

6 Cylinder Petrol Engine

Remove the front section of the engine undertray. From below, slacken off the pump pivot bolt. From above slacken the strap pivot and slide bolt. Pivot the pump away from the engine until the correct belt tension is obtained and holding it in this position tighten slide bolt followed by two remaining bolts.

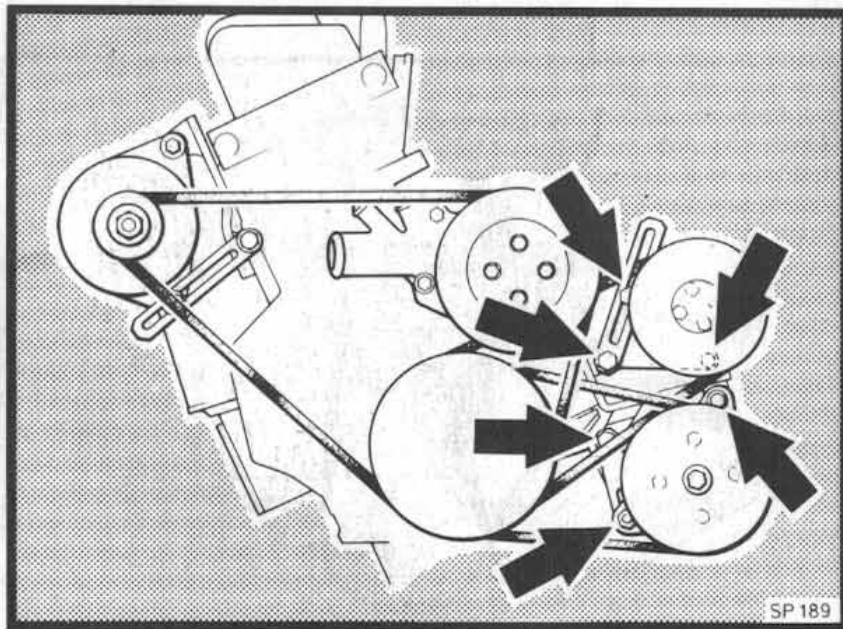

*6 Cylinder Petrol Engine
Power Steering and Vacuum Pumps*

4 Cylinder Engines

Remove the front section of the engine undertray. From below slacken off strap pivot and slide bolt. From above slacken the pump pivot bolt.

Swing the unit outwards away from the engine until correct belt tension is obtained. Holding it in this position retighten slide bolt followed by remaining two bolts.

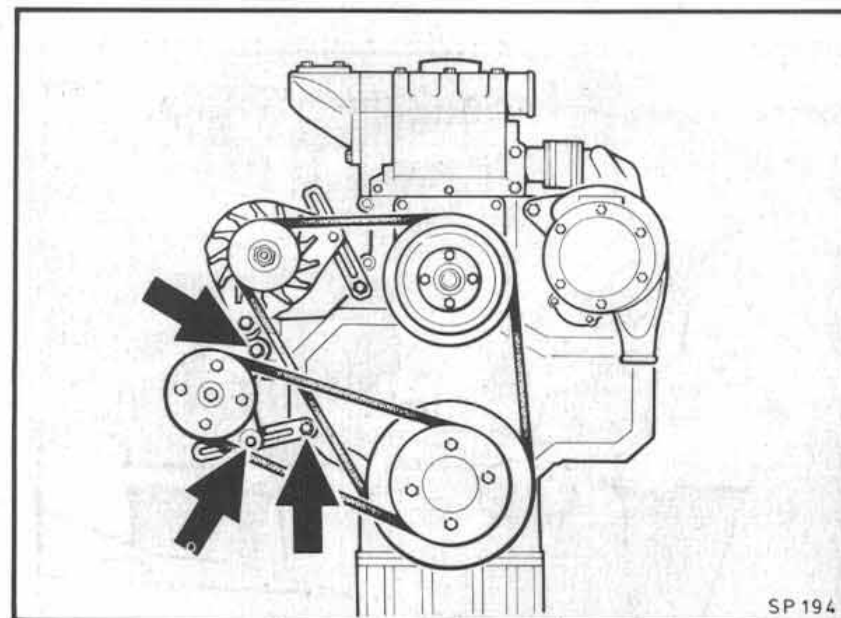

4 Cylinder Diesel

HYDRAULIC CLUTCH

Hydraulic System

The hydraulic fluid reservoir is located beneath the bonnet near the brake fluid reservoir.

Check the level of the fluid at regular intervals and if necessary top-up to within 12 mm (½ inch) from the filler aperture. Do not overfill otherwise clutch slip could occur when the fluid expands in hot weather. Check that the breather hole in the top edge of the filler cap is clear.

Topping-up should only be necessary at long intervals. Regular topping up or a sudden fall in fluid could indicate a leak in the system and this should be traced and rectified immediately by an authorised Dealer.

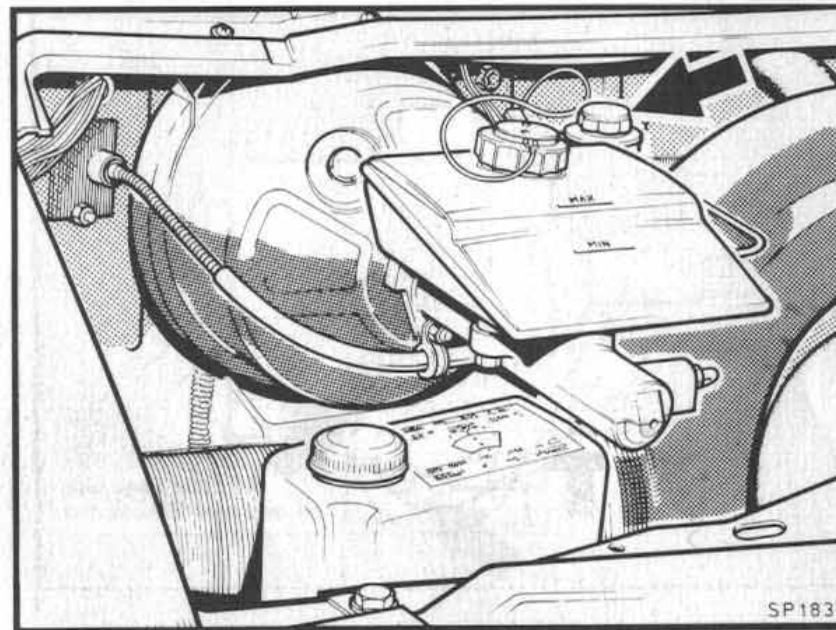

Clutch Master Cylinder

The clutch withdrawal mechanism is self adjusting and therefore requires no attention apart from lubrication at the withdrawal lever.

Fluid and Seal Changes

This is not a normal routine maintenance operation and must therefore be specifically requested when the vehicle is taken to the Dealer for service.

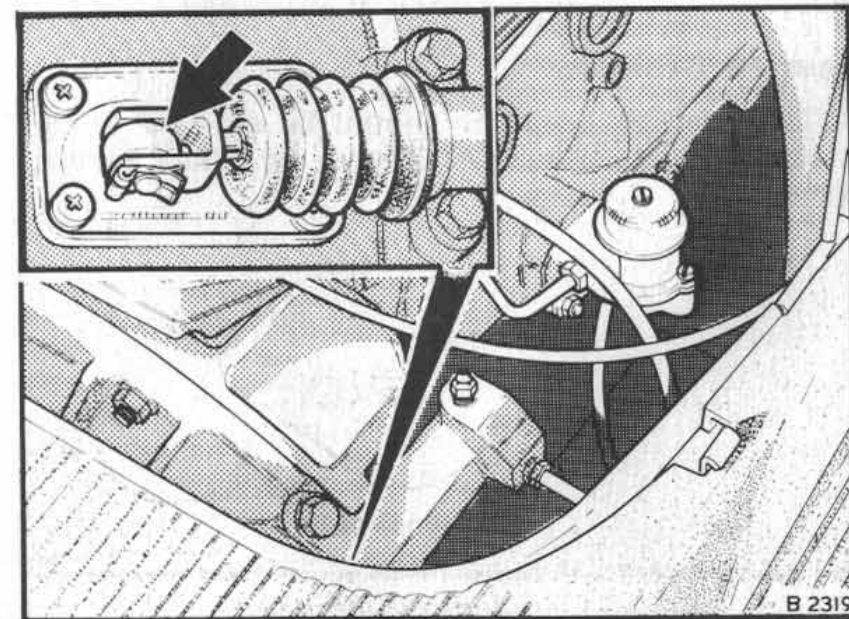

Clutch Slave Cylinder

GEARBOX

General

Examine the gearbox for leaks and rectify if possible by tightening bolts. If leakage persists take the vehicle to your Dealer for attention.

Checking the Oil Level

Check the gearbox oil level regularly and top-up if necessary. A combined oil level and filler plug on the left hand side of the gearbox is accessible from beneath the vehicle.

Check the oil level after the vehicle has been standing for some time and if possible ensure that the vehicle is standing on level ground. Top-up until oil reaches the filler plug aperture.

Gearbox Breather

The gearbox breather should be cleaned at the recommended intervals stated in the service schedule.

Changing the Oil

The oil must be changed at the intervals stated in the service schedule. See "Recommended Lubricants" for type of oil.

If possible change the oil when the vehicle has returned from a run and the oil is still warm. The drain plug which is magnetic will be found located in the bottom face of the unit. Ensure the plug is cleaned, refitted and tightened securely when draining is completed.

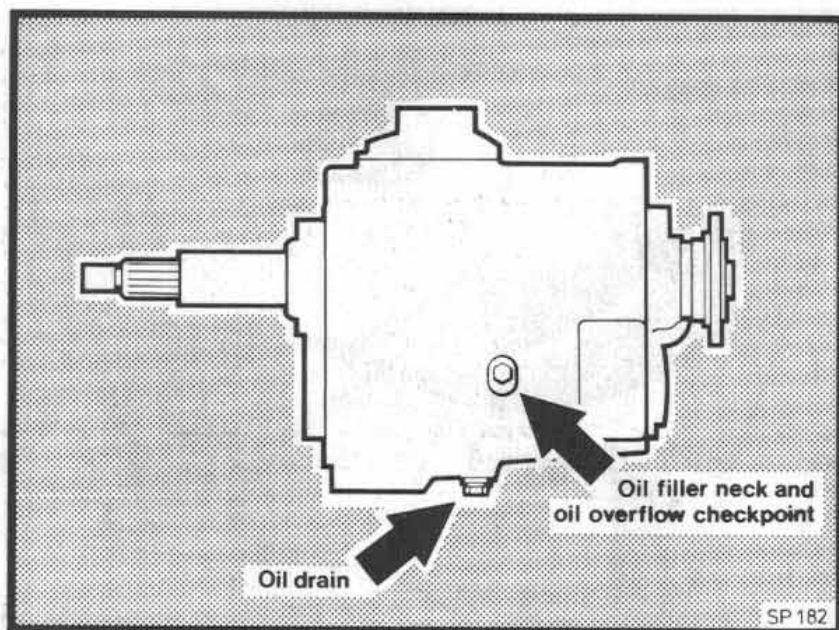

SP 182

HYDRAULIC CLUTCH

Hydraulic System

The hydraulic fluid reservoir is located beneath the bonnet near the brake fluid reservoir.

Check the level of the fluid at regular intervals and if necessary top-up to within 12 mm (½ inch) from the filler aperture. Do not overfill otherwise clutch slip could occur when the fluid expands in hot weather. Check that the breather hole in the top edge of the filler cap is clear.

Topping-up should only be necessary at long intervals. Regular topping up or a sudden fall in fluid could indicate a leak in the system and this should be traced and rectified immediately by an authorised Dealer.

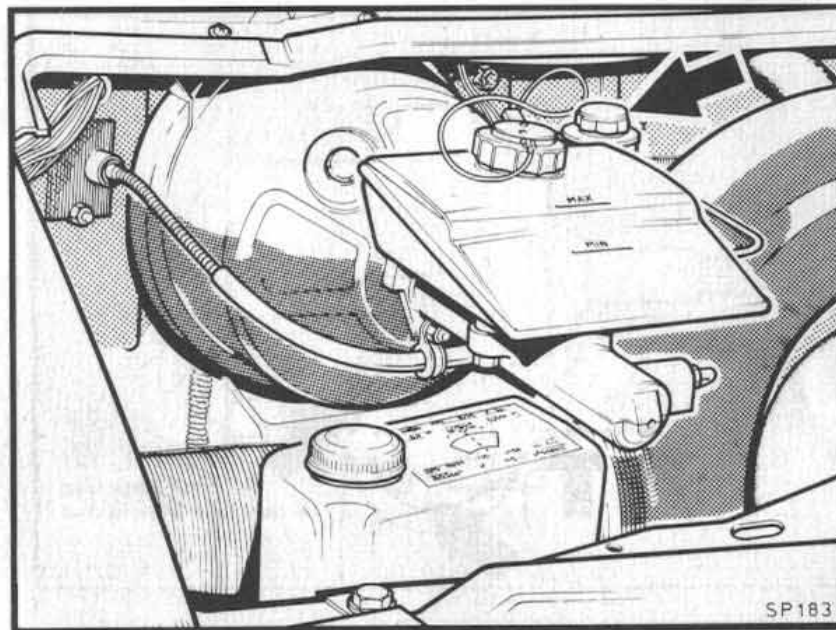

Clutch Master Cylinder

The clutch withdrawal mechanism is self adjusting and therefore requires no attention apart from lubrication at the withdrawal lever.

Fluid and Seal Changes

This is not a normal routine maintenance operation and must therefore be specifically requested when the vehicle is taken to the Dealer for service.

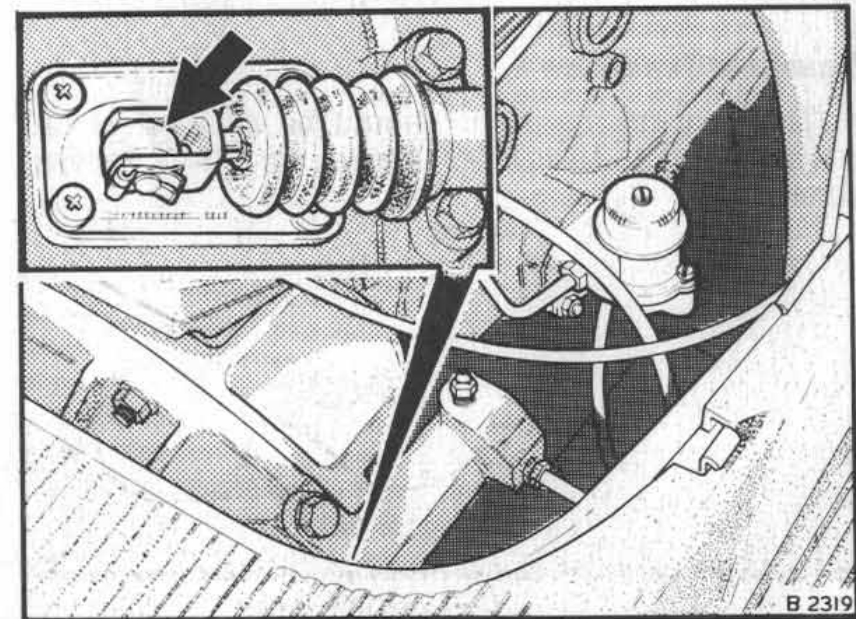

Clutch Slave Cylinder

GEARBOX

General

Examine the gearbox for leaks and rectify if possible by tightening bolts. If leakage persists take the vehicle to your Dealer for attention.

Checking the Oil Level

Check the gearbox oil level regularly and top-up if necessary. A combined oil level and filler plug on the left hand side of the gearbox is accessible from beneath the vehicle.

Check the oil level after the vehicle has been standing for some time and if possible ensure that the vehicle is standing on level ground. Top-up until oil reaches the filler plug aperture.

Gearbox Breather

The gearbox breather should be cleaned at the recommended intervals stated in the service schedule.

Changing the Oil

The oil must be changed at the intervals stated in the service schedule. See "Recommended Lubricants" for type of oil.

If possible change the oil when the vehicle has returned from a run and the oil is still warm. The drain plug which is magnetic will be found located in the bottom face of the unit. Ensure the plug is cleaned, refitted and tightened securely when draining is completed.

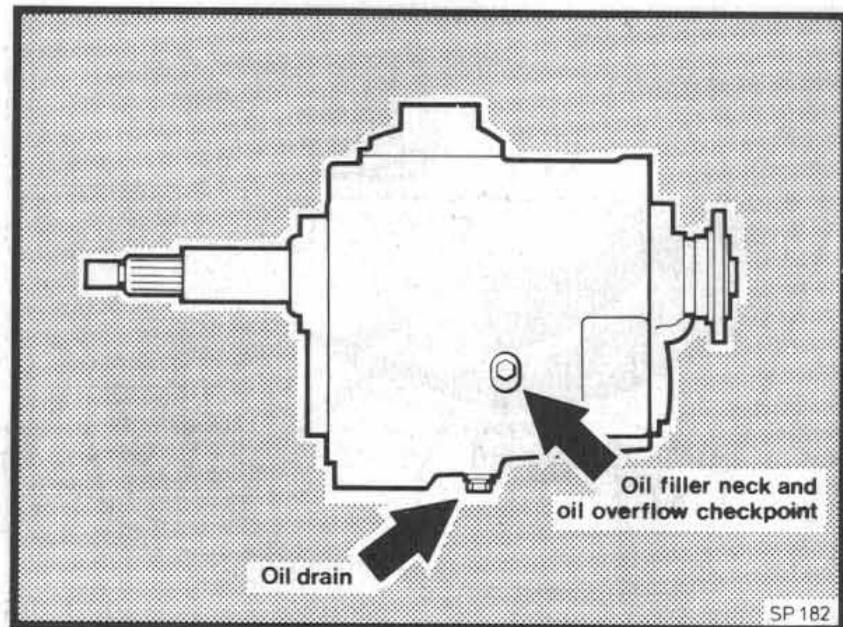

AUTOMATIC TRANSMISSION

Checking Fluid Level

The level of the transmission fluid must be checked at the recommended intervals and if necessary topped-up as follows:—

- 1 Remove the rear engine cover inside the cab.
- 2 Before removing the dipstick, wipe all dirt off the protective cap and top of the filler tube.
- 3 With the selector lever in "N" (neutral), engine running at idle speed and the fluid at normal operating temperature, approximately 79.4°C (175°F), the fluid level is correct if it is between the "Add ½ litre" and "Full" marks on the dipstick.
- 4 Refit the dipstick and rear engine cover.

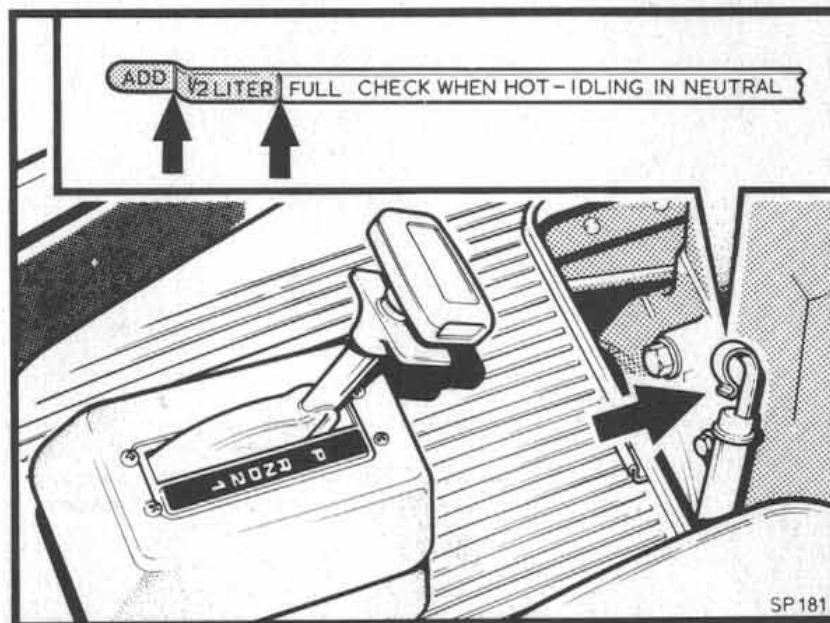

Dip Stick – Auto. Transmission

Changing Transmission Fluid and Filter

These operations should be carried out at the intervals specified in the service schedule. However, since draining and filter replacement necessitates removal of the sump, it is recommended that this work be entrusted to your Dealer.

CAUTION. Removing the sump from the transmission will expose the valve block. It is imperative that absolute cleanliness is observed since the ingress of the smallest piece of dirt or grit could seriously impair its operation.

Band Adjustment

This operation should be carried out when the fluid and filter changes are carried out. Adjustment of the bands is critical to the correct function of the unit and should therefore be left to your Dealer.

PROPELLER SHAFT

Lubrication

Lubrication nipples are incorporated in the universal joints and sliding sleeves. Apply grease of the correct grade at the recommended intervals.

The centre bearings are packed with grease on assembly and require no further attention.

Check the tightness of coupling flange nuts.

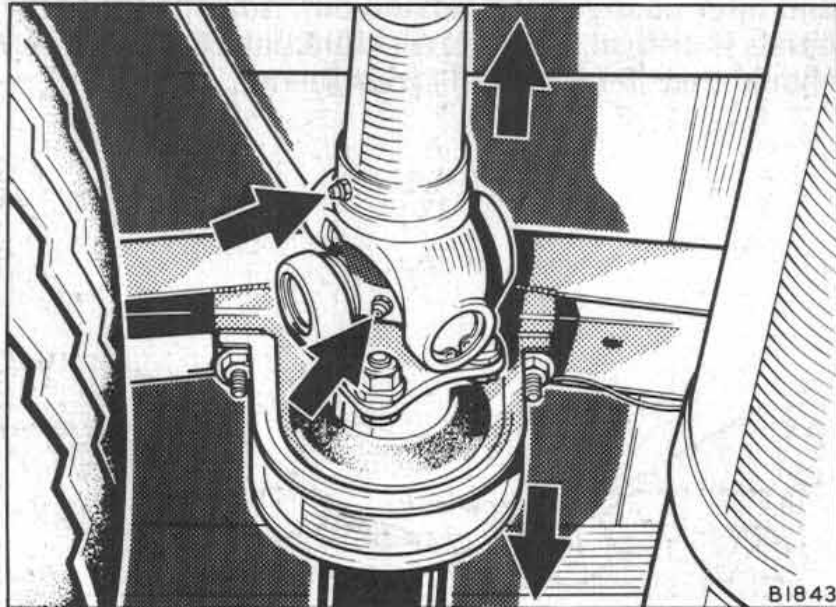

REAR AXLE

General

The level of the oil in the rear axle must be checked regularly and topped up if necessary. In addition the oil must be changed completely at the intervals stated in the service schedule.

Check the unit for leaks and rectify if evident by tightening appropriate nuts or bolts. A persistent leak or a leak from the front of the differential housing should be dealt with by your Dealer.

Checking Oil Level

A combined oil filler and level plug will be found located in the rear cover.

With the vehicle standing on level ground clean the area around the filler plug (A) remove the plug and top up with oil of the correct grade until level with the plug orifice. Do not overfill. Replace the filler plug.

To Drain and Refill

The rear axle oil should be renewed at the recommended intervals.

Draining the oil is best done when the axle is warm and the lubricant flows more easily.

- 1 Wipe the area around the drain plug (B) – and remove the drain plug.
- 2 Allow the oil to drain completely.
- 3 Replace the drain plug.
- 4 Wipe the area around the filler plug and remove the plug. Fill with the correct grade of oil until level with the filler plug orifice. Do not overfill.
- 5 Replace the plug.

Breather

A breather (C) located in the top of the rear axle differential casing must be removed and cleaned at the intervals stated in the service schedules.

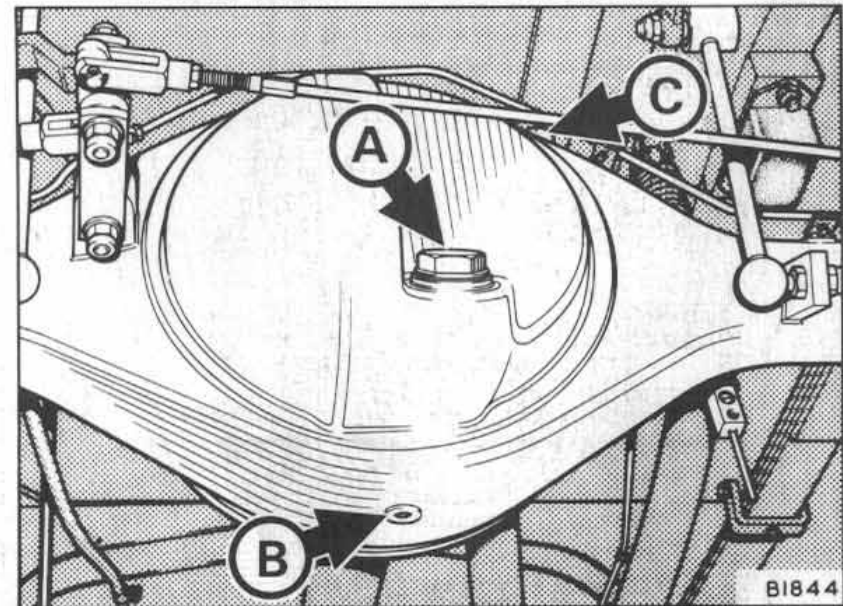

B1844

WHEEL HUBS

Hub Bearing End Float

The hub bearing end float should be checked by your Dealer at the recommended intervals.

Hub Bearing Lubrication

The hub bearings should be cleaned and repacked with fresh lubricant by your Dealer at the recommended intervals.

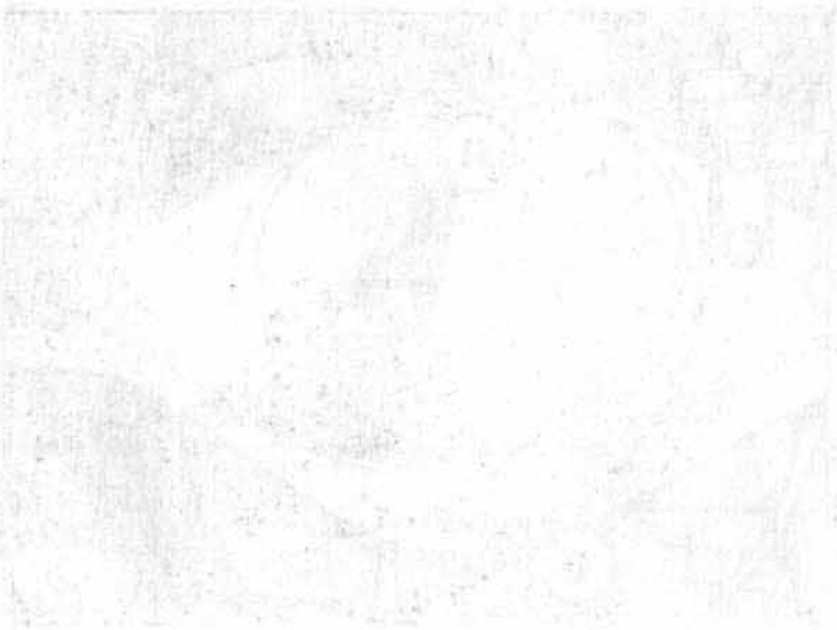

MANUAL STEERING

Steering Free Play

Excessive free movement at the steering wheel is not permitted and this should therefore be checked regularly. If evident, take the vehicle to your dealer for rectification.

Steering Box Oil Level

The oil level must be checked at recommended intervals by removing the combined filler/level plug located in the top of the steering box at the front. If necessary, top up with the correct grade of oil until the level reaches the filler plug hole. Refit the plug securely.

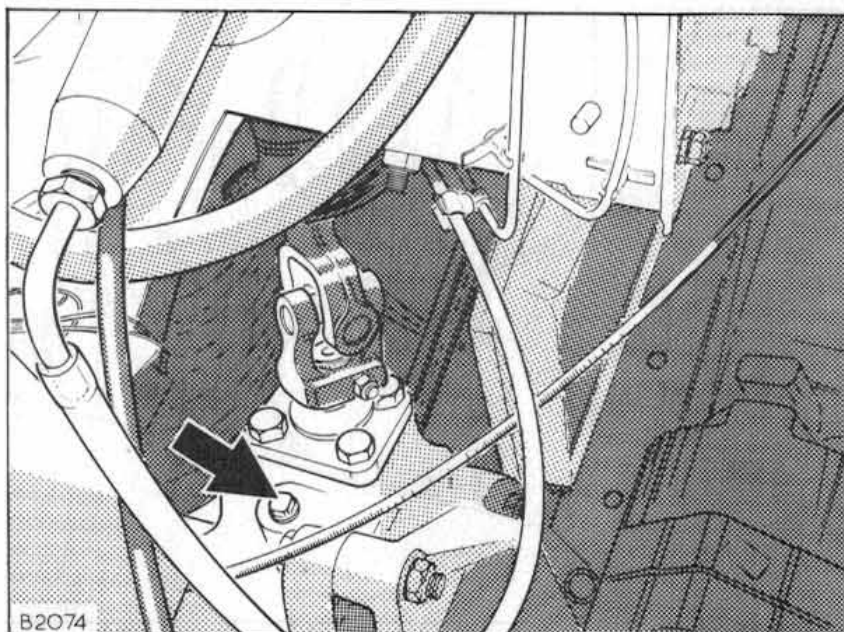

Swivel Pin Lubrication

Swivel pin lubricators are located at the top and bottom of the swivel pins. Apply grease of the correct grade at the recommended intervals.

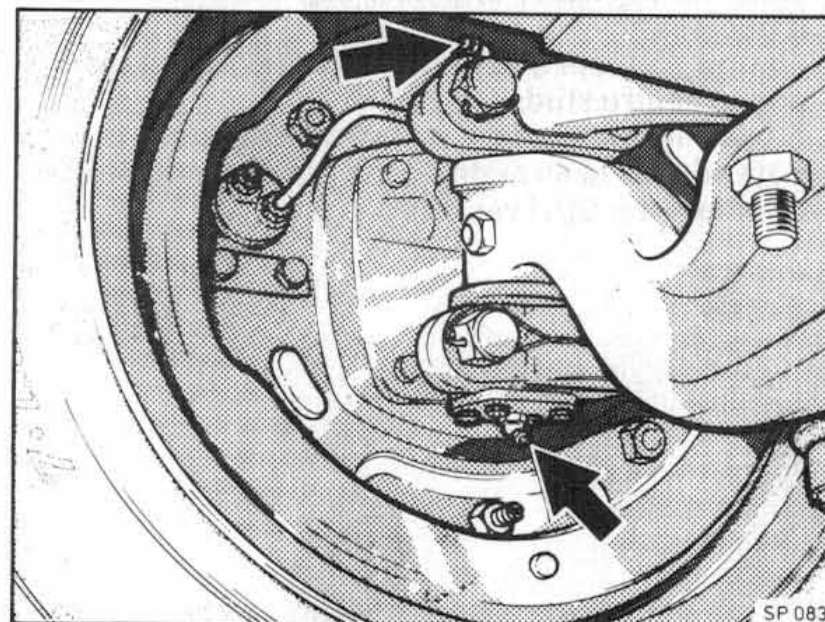

POWER STEERING RESERVOIR

Checking the Fluid Level

The reservoir which is located under the bonnet has a dipstick fitted to the filler cap. Before removing the cap clean the outside thoroughly. If necessary top-up the reservoir to the level mark on the dipstick.

Reservoir Filter

The filter which is located within the reservoir unit must be renewed at the recommended intervals.

Proceed as follows:-

- 1 Thoroughly clean the outside of the reservoir.
- 2 Remove the centre stud nut and lift off the cover.
- 3 Remove the spring and spring seat and lift out the element.
- 4 Examine the cover and filler cap seals and renew if necessary.
- 5 Fit new element and locate spring seat and spring on the centre stud.
- 6 Fit and secure cover – do not overtighten.
- 7 With wheels in straight ahead position check fluid level and top-up if required.

Draining Steering Fluid

If for any reason it becomes necessary to drain the system, proceed as follows:-

To Drain

Apply the parking brake; jack-up and support the front axle.

Remove the reservoir cover (for filter renewal).

Place a suitable container beneath the steering box and disconnect the two pipes from the unit.

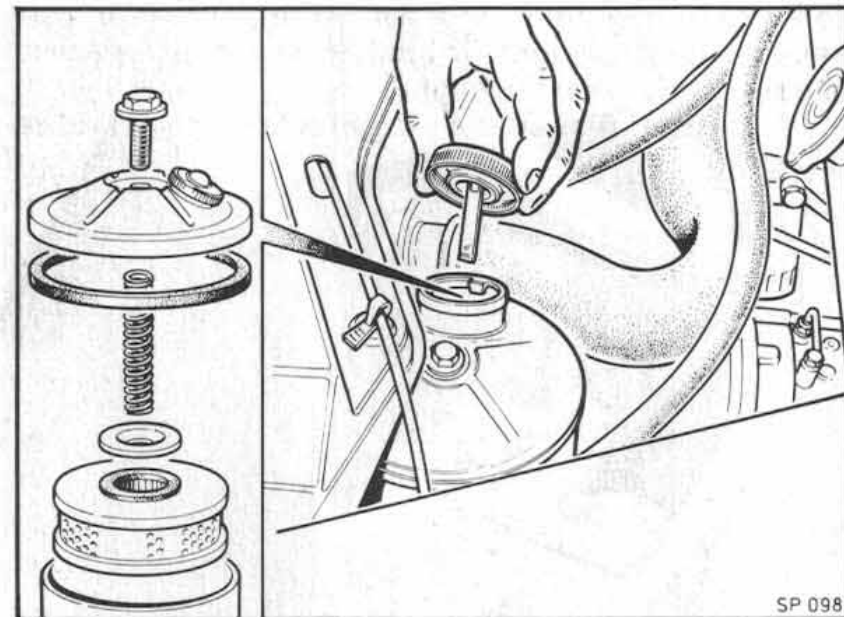

SP 098

Note The fluid will run out of the box onto the front spring assembly. It is therefore advisable to use a tray type container.

Operate the steering from lock to lock several times until fluid ceases to flow.

Immobilise ignition (petrol) or fuel system (diesel) and turn the engine over on the starter (using short applications) to drain the fluid which is trapped within the power steering pump.

When fluid ceases to flow reconnect pipe unions.

To Refill and Bleed

Having fitted a new element in the reservoir refill with fresh fluid until the element is just covered. Start the engine and allow it to idle. As soon as the fluid in the reservoir starts to drop, top-up to maintain the level.

Bleed the system by turning the steering from lock to lock topping-up as necessary. Continue until level remains constant and air bubbles cease to appear in the reservoir. Stop the engine.

Refit reservoir cover and top-up to correct level on dipstick.

SUSPENSION

Leaf Springs

Normally these require only periodic cleaning to allow visual checks in respect of spring condition e.g. cracks or breaks. Any repairs or replacements should be entrusted to your Dealer.

Dampers - Telescopic type

Telescopic type dampers require no attention except for periodic checks for leakage.

BRAKE SYSTEMS

General

The foot brake system is hydraulically operated with vacuum or air assistance to front and rear brake assemblies.

On vacuum hydraulic models the handbrake is cable operated and acts on the rear wheels only. On air hydraulic models, parking is by means of a spring brake unit which operates when air is released from the cylinder. Adjustment of brake shoe or pad clearance is made by foot brake application on the front brakes and by foot or handbrake application on the rears.

WARNING

It is important that the brake system be maintained to a high degree of efficiency at all times.

The following notes should be observed:-

- 1 Regularly check all visible parts of the system for signs of leaks. Rectify as necessary immediately.
- 2 Ensure that the brake fluid reservoir is kept topped up to its correct level.
- 3 Inspect all pipelines, brake hoses and external rubber boots for signs of wear, damage and deterioration. Rectify as required.
- 4 Examine brake shoes and pads for wear at regular intervals as indicated in the service schedule.
- 5 Renew the hydraulic fluid and seals as recommended in the Planned Maintenance Schedule.

A load sensing valve is incorporated which regulates the braking effort applied at the rear wheels relative to the load on the rear axle.

The system also incorporates warning lights for handbrake 'on', hydraulic brake fluid low level and low vacuum/air. (See "Brake Warning Light and Buzzer").

AIR SYSTEM

Compressed air is supplied through a dual brake pedal valve to a tandem actuator which in turn operates a tandem hydraulic master cylinder. The air system is split, and each section is supplied with air by separate service reservoirs. Each reservoir is fed by the sensing reservoir through a quadruple protection valve. The hydraulic circuit is also split, the separate chambers of the master cylinder each operating the brake units on one axle. In this system failure of one part of the air system allows reduced but effective braking on both axles, whilst a failure of one part of the hydraulic system provides full braking on one axle.

The secondary brake is considered to be the unfailed part of the system.

The hand control valve on this system provides park braking. Air exhausted from a single spring brake unit on the rear axle releases a powerful spring to operate the rear brake units mechanically through a compensator linkage.

VACUUM SYSTEM

Vacuum supply is provided by an exhauster unit.

All hose connections should periodically be checked for leaks and general deterioration. Tighten joints where required and have any apparent loss of vacuum rectified by an authorised Dealer.

Decarbonising the Compressor

The compressor should be checked for carbon build up, and decarbonised if necessary, at the recommended intervals by your Renault Dealer.

Dealer.

Sensing Reservoir

Safety Valve

A safety valve (C) is fitted to the sensing reservoir to prevent excessive pressure build-up due to non-functioning of the governor valve cut out.

Automatic Drain Valve

An automatic drain valve (A) is fitted to the air sensing tank and condensate is ejected automatically. At the recommended intervals press the plunger to empty the air tank. Remove drain valve assembly and clean the filter with diesel fuel. Dry the filter before re-assembly.

Emergency Charging of Air System

In the event of air pressure being lost by failure of the air charging system it is possible to charge the system from an external source.

External charging is accomplished by connecting a compressed air source to a Schrader-type valve (B) located on the sensing reservoir.

IMPORTANT. External charging must only be used to assist removal of the vehicle for subsequent repair.

It is not possible to release the parking brake without full air pressure except by winding off. See "Spring Brake Unit".

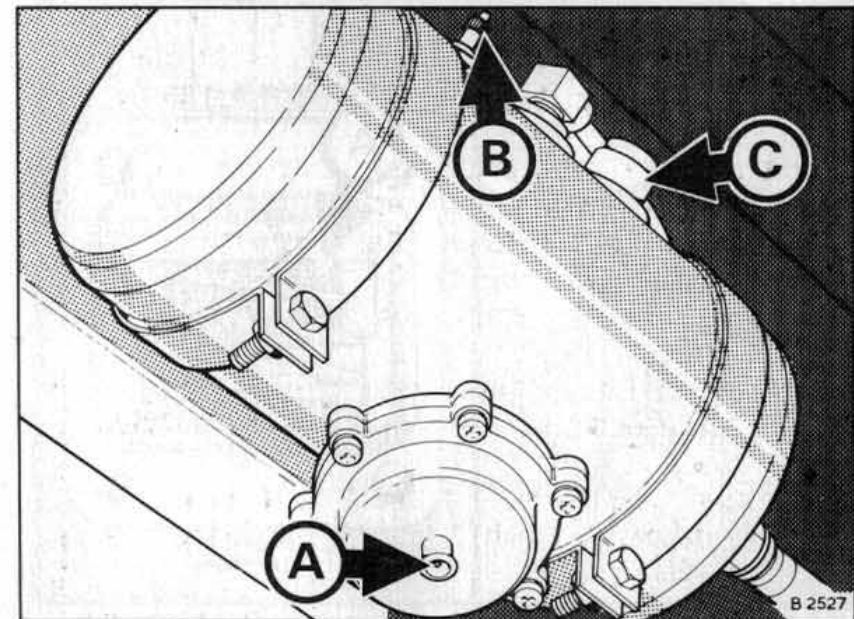

Sensing reservoir

Air Line Filters

Three air line filters are fitted in the air system.

One in line filter (A) is fitted adjacent to the quadruple protection valve, and one in each inlet port of the foot valve.

At the recommended intervals the in line filter should be removed and cleaned.

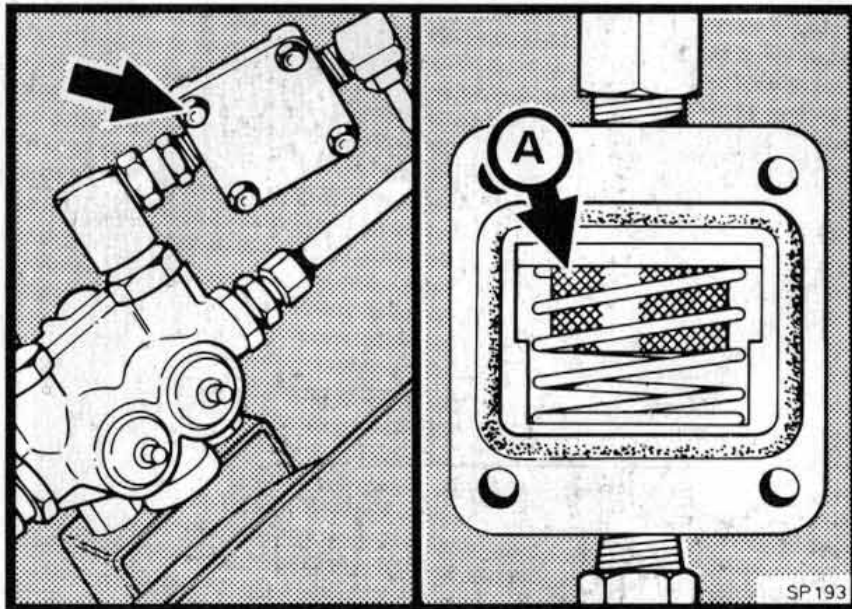

Spring Brake Unit

WARNING

Under no circumstances should this unit be touched except by experienced personnel with special equipment. The compression of the spring is very high and, if released without proper equipment, can inflict serious injury.

The parking brake is operated by a spring unit located in a chamber on the rear axle.

A 'wind-off' is incorporated in the actuator to release the rear brakes if it is required to move the vehicle when a fault in the air system or hand control valve will not release the brakes in the normal way. A special spanner is provided with each vehicle.

WARNING

The vehicle must not be driven on public roads with the mechanism wound back. Any attempt to drive it would be illegal and dangerous.

To Wind-off

- 1 Chock the wheels, couple the vehicle to the towing unit with a rigid tow bar, and apply the parking brake on the towing unit.
- 2 Roll back the gaiter from the pull rod and mark the position of the locknut relative to the pull rod. Slacken the locknut and rotate the pull rod sleeve (A) clockwise, ensuring the pull rod does not turn in the fork end.

Initial movement will relax the power spring, then the pull rod will lengthen to release the rear brakes.

- 3 The wind-off mechanism must be reset to the original condition by reversing the procedure when the appropriate repairs have been completed.

Lubrication

Two lubricators (B) are situated on the handbrake compensator unit located on the rear axle. Lubricate at the recommended intervals.

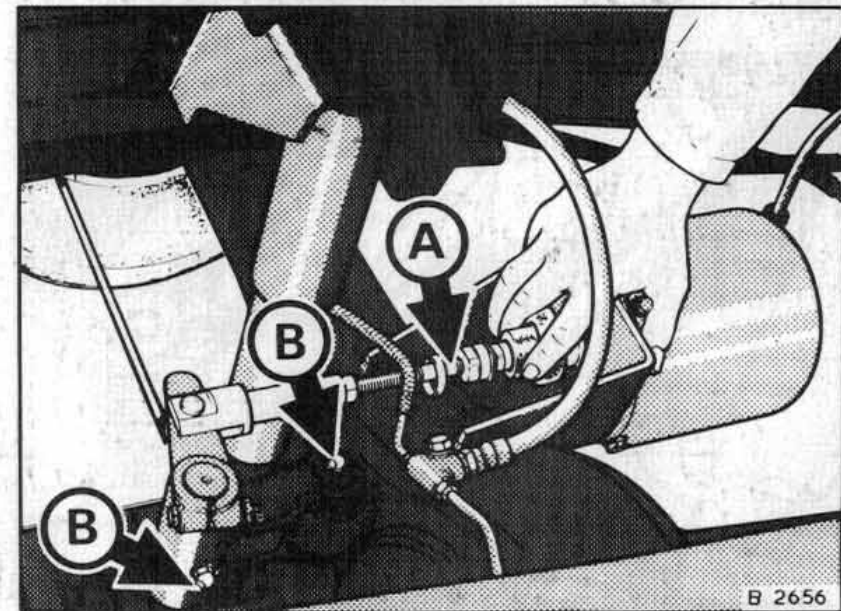

B 2656

HYDRAULIC SYSTEM

The hydraulic system operates with two independent circuits, one supplying the front and the other the rear brakes. If a leak develops in one circuit the other is unaffected. Regularly check the hydraulic system for leaks, damage, chafing or corrosion. Have any defects rectified immediately.

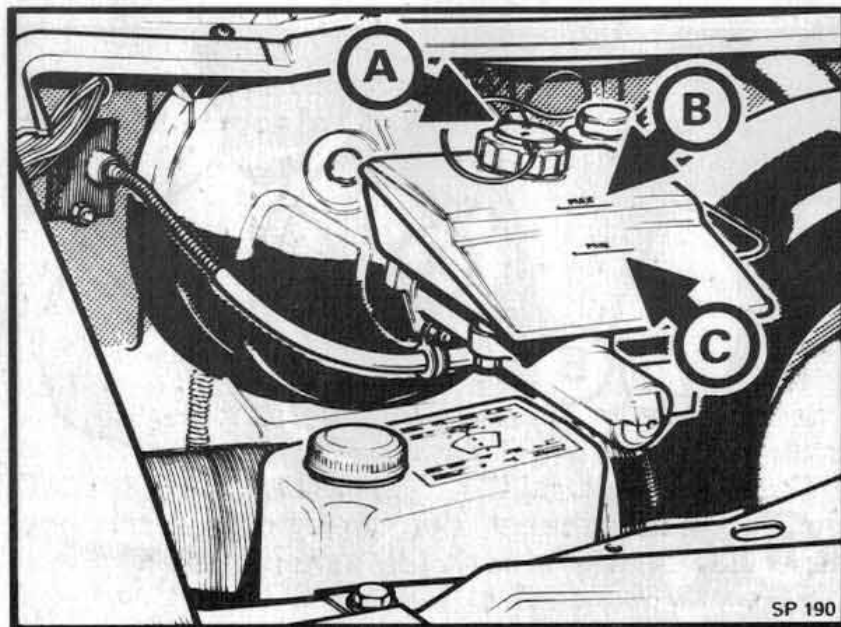

Vacuum servo unit

Checking Fluid Level

The brake fluid reservoir is located beneath the bonnet on vacuum hydraulic models or behind the cab, on the outside of the chassis sidemember on air hydraulic models. The translucent container allows the level to be seen without removing the cap.

Correct fluid level (B) is indicated on the front face of the reservoir marked 'MAX'. Do not overfill.

Never allow the fluid level to fall to the 'MIN' mark (C).

Fluid levels should be checked physically at regular intervals. Frequent necessity for topping up indicates a fluid leak which must be rectified immediately.

If topping up is necessary, clean the area surrounding the cap thoroughly before removal. Top up with clean unused fluid to the correct specification, replace the cap.

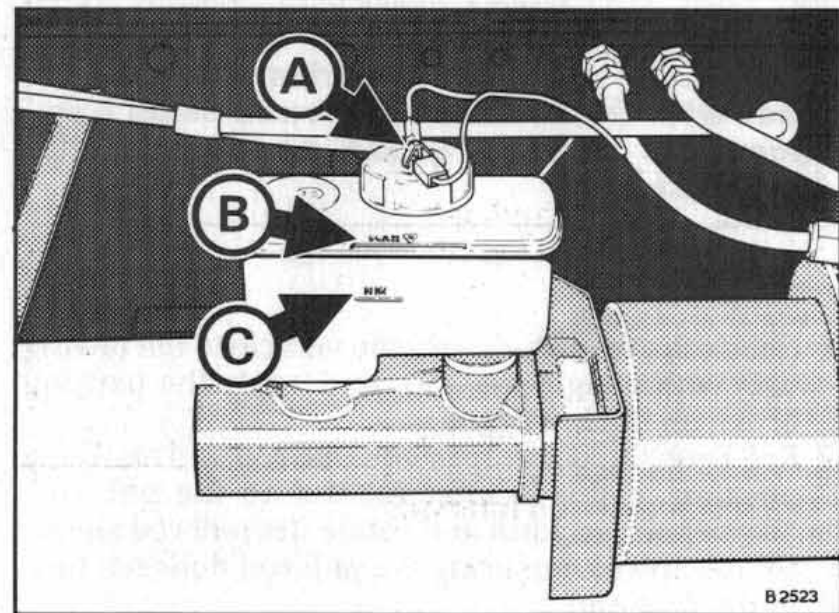

Air hydraulic model

To check operation of warning system

To check the low level warning light bulb simply open the cab door. The warning light should illuminate.

To check the operation of the low level warning switch (A) mounted in the cap on the fluid reservoir, proceed as follows:-

- 1 Ensure that the cab interior lamps are switched to the courtesy position i.e. lamps light only when doors are open.
- 2 Close both cab doors.
- 3 Press the filler cap and check that cab interior lamps illuminate.

Bleeding the System

This is not a routine maintenance item and should only be necessary when air has entered the system. Entrust this work to your authorised Dealer if required.

Hydraulic Pipe Connections

Check for leaks and damage of pipe lines, unions, flexible hoses, etc.: if tightening of unions is necessary overtightening must be avoided - THIS WORK SHOULD BE ENTRUSTED TO AN AUTHORISED DEALER.

Due to the use of salt to disperse snow and ice on roads during winter months, it is important that brake pipes are checked (without dismantling) for corrosion at the recommended intervals.

Changing Brake Fluid, Seals and Hoses

In the interest of safety it is recommended that hydraulic fluid, seals and flexible hoses are renewed at the intervals stated in the Service Schedule.

This work must be entrusted to your Dealer.

LOAD SENSING VALVE

The load sensing valve regulates the braking pressure passing to the rear brakes so that maximum pressure is only available when the vehicle is fully laden. As the vehicle's load is reduced the valve automatically lowers the braking pressure.

Accurate setting of the valve is essential and should only be carried out by your Dealer. A brake data plate is located on the vertical panel of the step well showing the valve setting dimension 'Y' for your vehicle. The 'Y' dimension is determined using the unladen weight of the rear axle and is set before delivery to the operator. Any alteration which may change the unladen weight e.g. change of body will necessitate re-setting the valve. A change of rear springs will also require valve re-adjustment. A new brake data plate will have to be fitted showing the new unladen weight and 'Y' dimension.

During the normal life of the vehicle the valve will require re-adjustment due to spring settlement (especially during its early life) at the periods shown in the service schedules.

BRAKE LINING AND PAD WEAR

Disc brakes

Disc brakes are self adjusting.

Brake pad wear can be checked after removing the front wheels as follows:-

S 46, S 56 haulage – Through the front opening in the caliper.

S 56 P.S.V., S 66 – Through the gap (A).

Minimum disc pad thickness all models is 4mm.

S 56 P.S.V., S 66 – The caliper slide pins, rubber boots and bushes (B) should be checked or renewed at the intervals stated in the servicing schedule.

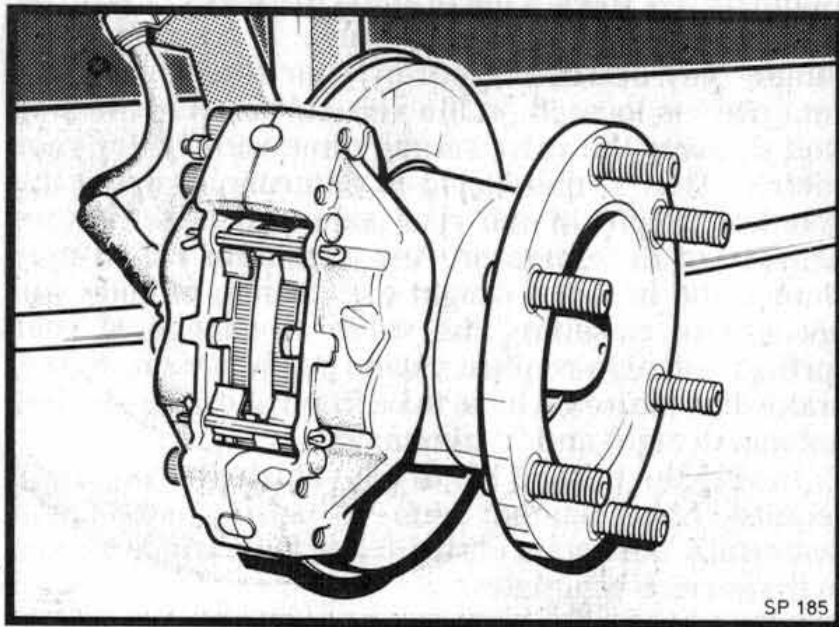

SP 185

Front Disc Brake S 46, 56 haulage.

Drum brakes

All drum brakes are self adjusting.

Rear brakes have lining inspection holes (A) protected by covers.

Front brakes (A/H only) do not have lining inspection holes.

Front and rear brakes have slots (B) which give access to manually adjust the brakes.

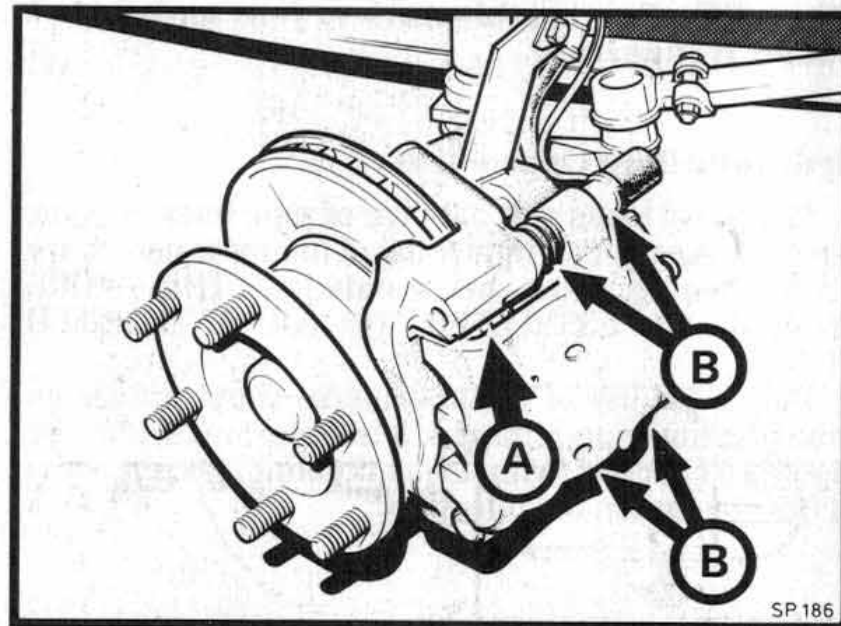

SP 186

Front Disc Brake S 66, S 56 P.S.V.

HANDBRAKE

Occasionally lubricate the handbrake pivot, ratchet and pawl assembly. Also lubricate all clevis pins in the cable linkage.

Normal handbrake travel should be 6 to 8 clicks of the ratchet as the lever is applied. Excessive travel indicates stretch in the cable linkage which must be taken up by accurate re-adjustment carried out by your Dealer.

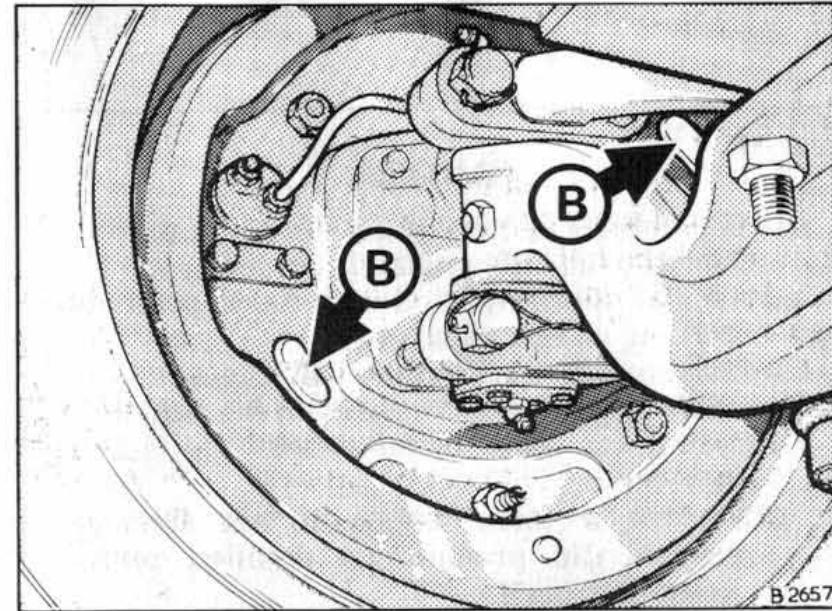

Front Brake – Air hydraulic models

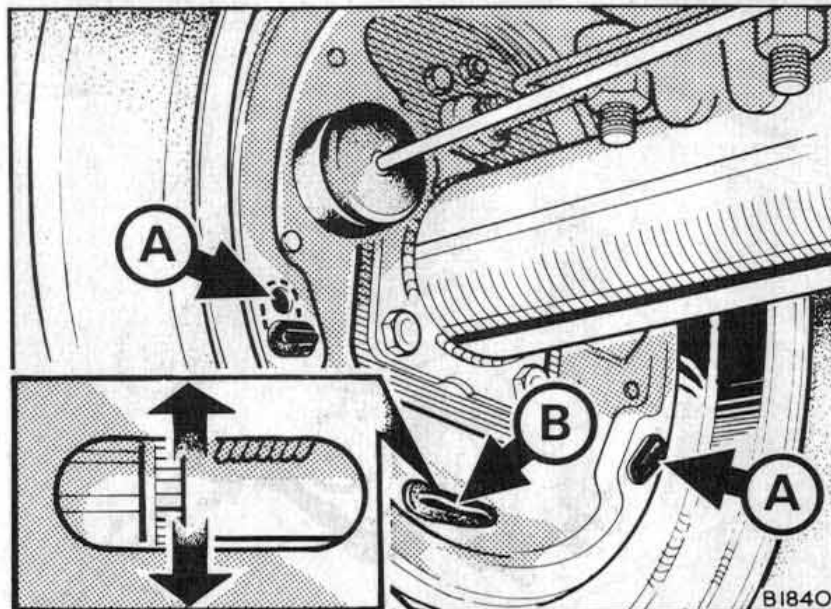

Rear Brake – Vacuum/Hydraulic models

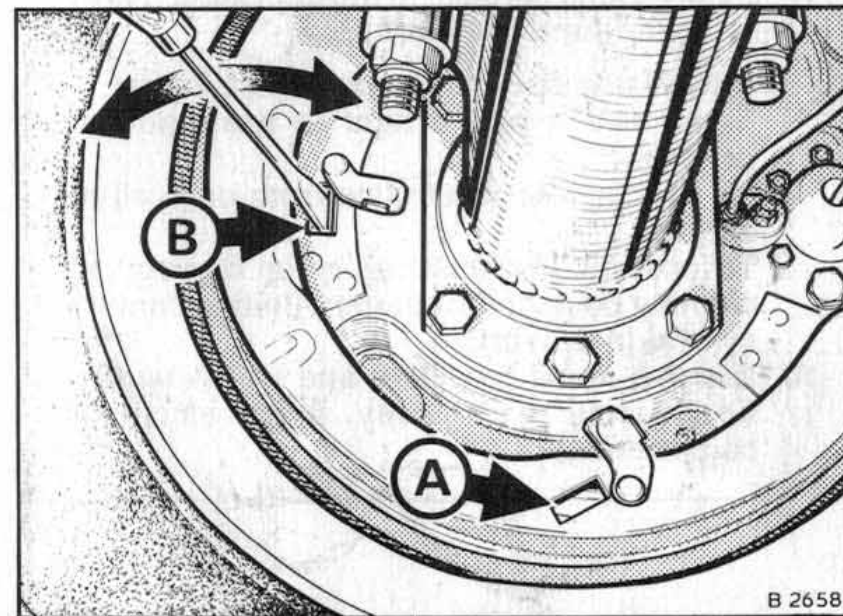

Rear Brake – Air hydraulic models

CAUTION

- 1 The vehicle battery must never be disconnected whilst the engine is running.
- 2 Always disconnect the battery prior to working on electrical units.
- 3 Disconnect the battery if electric arc welding is to be carried out on the vehicle.
- 4 Disconnect the battery prior to boost charging.
- 5 If using a slave battery to aid starting, observe the precautions detailed under "Jump Starting".

Failure to observe the above instructions can result in serious damage to the alternator, short circuiting or burnt out wiring.

- 6 Always use distilled water for topping-up.
- 7 Never use a naked light to examine the battery.
- 8 Do not transfer electrolyte from one cell to another.
- 9 To prevent personal injury or damage to clothing do not allow battery fluid to contact eyes, skin or fabrics.
- 10 Remove metal jewellery and watch bands. Keep tools well away from electrical connections.

BATTERY

One 12 volt or two 12 volt batteries (in parallel) are mounted on a carrier located behind the cab on the chassis side member.

Access on van models is through the floor panel illustrated below. To remove the panel release the four fasteners.

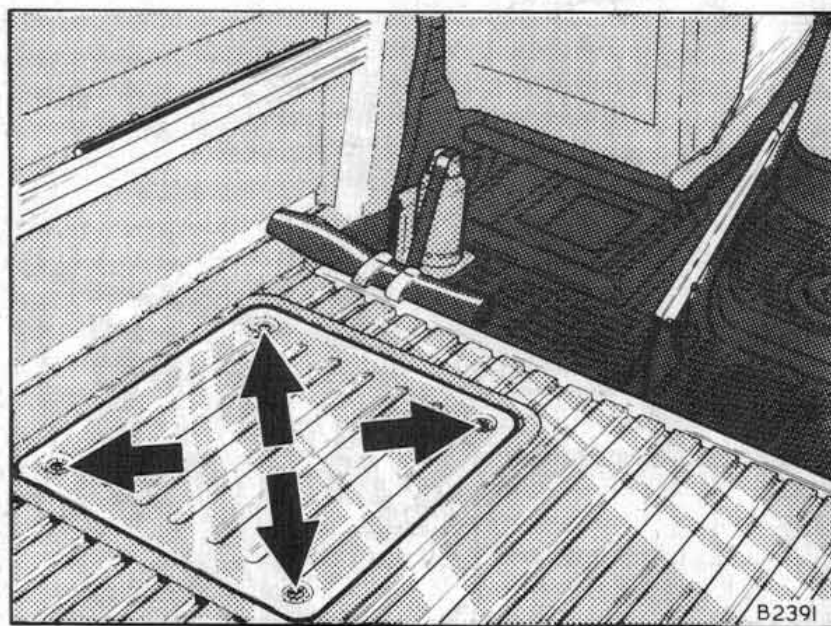

Battery cover – high capacity van

Maintenance

Low maintenance batteries are fitted and under normal operating conditions the battery electrolyte level should be checked annually.

With the battery on a level surface, check the electrolyte level by removing the vent plugs, raising the vent cover or viewing through the container, depending on the type of battery. If the level is below the tops of the separators or splash guards, topping-up is required. Do not top-up unnecessarily as this may overflow the battery – as a general rule, if you can see liquid above the separators, don't add any. If the battery is flat, recharge it before checking the electrolyte level. As a guide, always try to top up when the battery is fully charged.

NOTE. When two batteries are fitted always renew them in pairs.

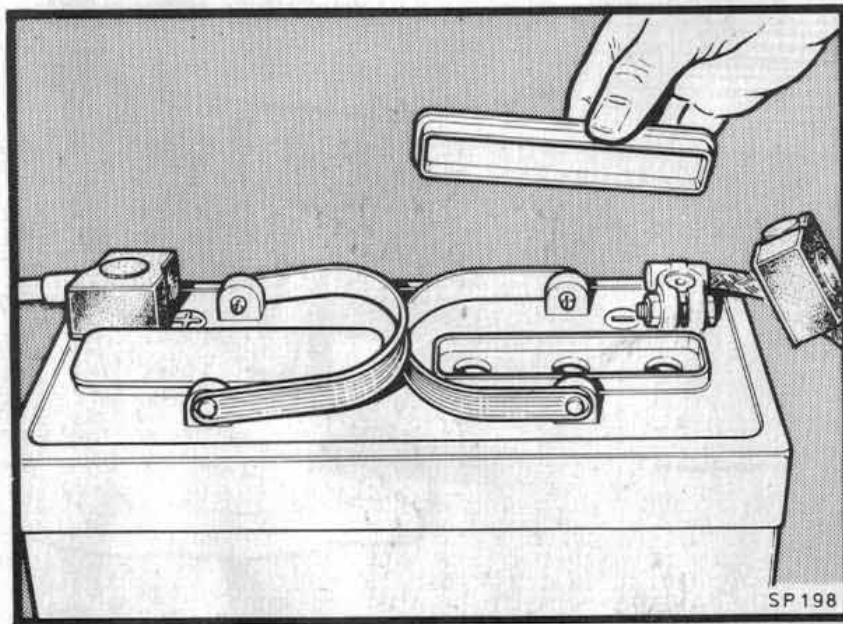

Battery – topping up

Battery Terminals

Terminal posts should be kept clean and protected by petroleum jelly.

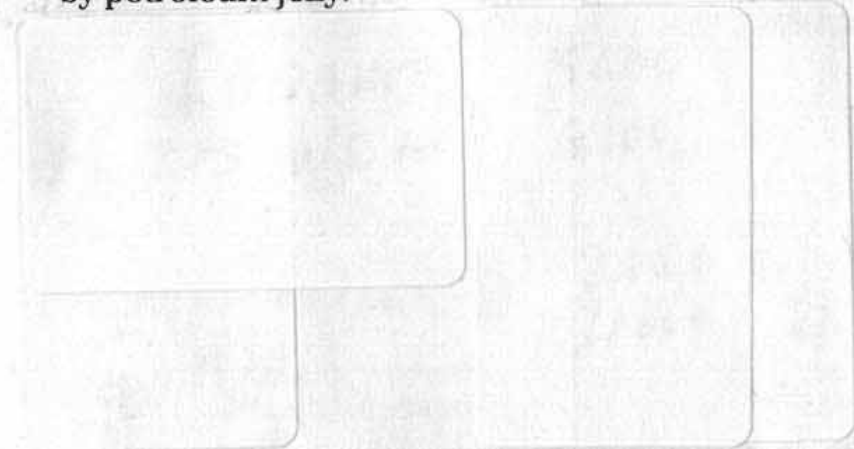

Jump Starting with a Booster Battery

Switch off the ignition and headlights.

Remove the filler caps from both the booster battery and the discharged battery. Check that the electrolyte is at the proper level.

Connect one jump cable between the POSITIVE (+) POSTS of the batteries.

Connect one end of the other jump cable to the NEGATIVE (-) POST of the booster battery. Connect the other end of the cable to the engine end of the battery earth cable. DO NOT CONNECT TO THE NEGATIVE POST OF THE DISCHARGED BATTERY, as a flash may occur on connection or disconnection.

Switch on the ignition and operate the starter.

After the engine is started, or if it fails to start, the cables must be disconnected in the following order:–

- 1 Negative cable at the battery earth cable.
- 2 Negative cable at the negative post on the booster battery.
- 3 Cable between the positive posts of the batteries.

electrical equipment

Alternator and Starter

Check the units occasionally to ensure that they are secure. Also check that electrical connections are secure and that wires are not chafing.

Fuse Box

Twelve fuses are carried in a separate fuse box mounted below the facia and to the left of the steering column. Each fuse is of an 8 amp capacity.

Fuses protect the circuits as indicated in the following:-

- Fuse 1 Headlamp dipped beam (right hand).
- Fuse 2 Headlamp dipped beam (left hand).
- Fuse 3 Instruments, switches and gauge illumination, and right hand side, tail and rear number plate lamps.
- Fuse 4 Side, tail and number plate lamps (left hand).
- Fuse 5 Headlamp main beam (right hand).
- Fuse 6 Headlamp main beam (left hand).
- Fuse 7 Horn, interior lights, cigar lighter and brake fluid low level warning light.
- Fuse 8 Flasher unit.
- Fuse 9 Heater blower, coolant temperature and fuel gauges.
- Fuse 10 Rear fog lamps.
- Fuse 11 Screen washer, wiper motor and reversing lamps.
- Fuse 12 Stop lamps.

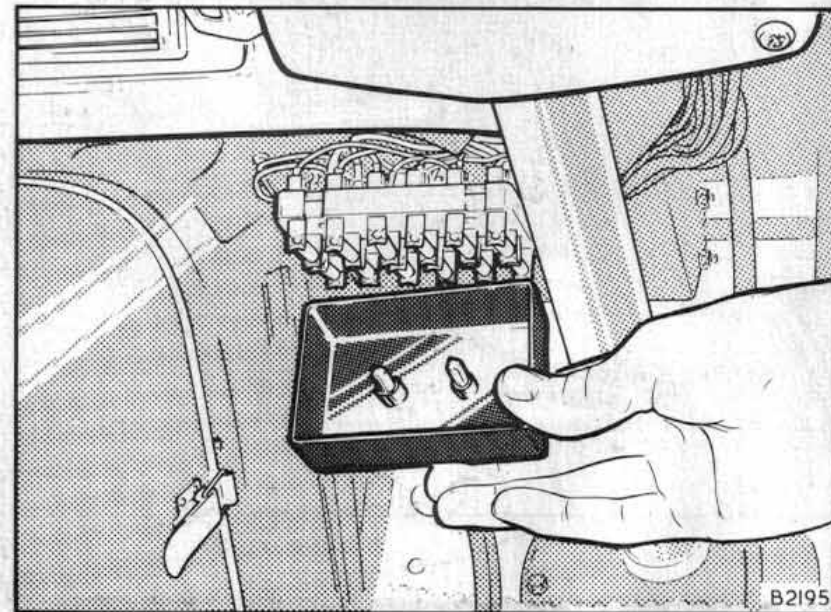

Fuse box

BULB RENEWAL

Side Lamps

These are incorporated in the headlamp reflectors. Bulb holders are a push fit into moulded rubber reflector mounted grommets.

Headlamp Bulbs

Unclip and hinge away the cover.
Unplug the connector.
Release the spring clip and withdraw bulb unit.
Insert the new bulb unit with the centre lucar uppermost, locating the three lugs properly in the back of the reflector.
Do **not** touch the glass of the bulb with bare fingers.

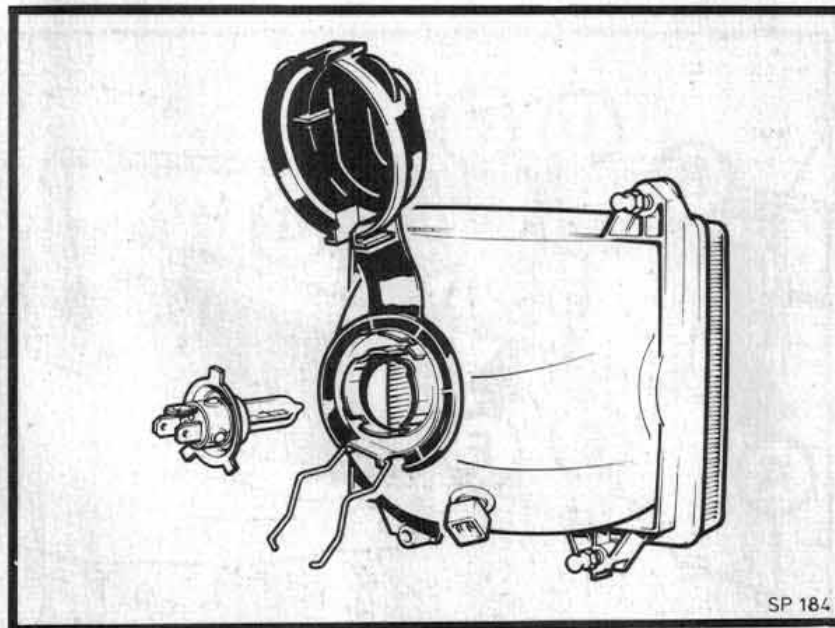

Headlamp

electrical equipment

Headlamp Adjustment

Adjustment and alignment is achieved by the diagonally opposite adjusting screws.

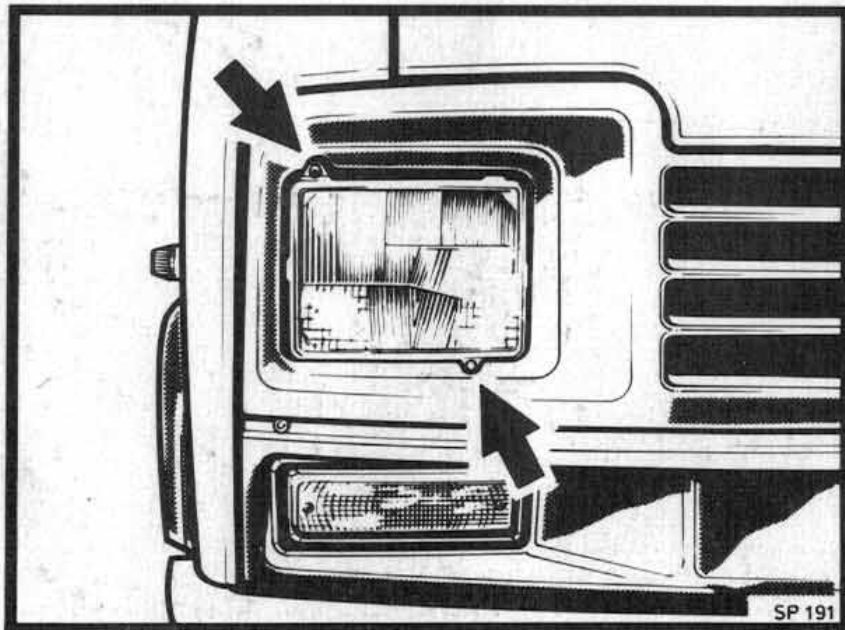

Headlamp-adjustment

Rear Lamps - Truck Model

To gain access to a bulb, release clip 'A' and hinge the bezel away from the lens. Remove the lens carefully by easing it out from the lip around the lamp base. To refit lens, ensure the plain window is at the bottom and carefully fit to the lamp base making sure that it fits snugly into the lip which forms a water tight seal. Swing the bezel back over the lens and secure under clip 'A'.

- B - Fog light
- C - Reverse light
- D - Tail light
- E - Number plate light
- F - Stop light
- G - Direction indicator

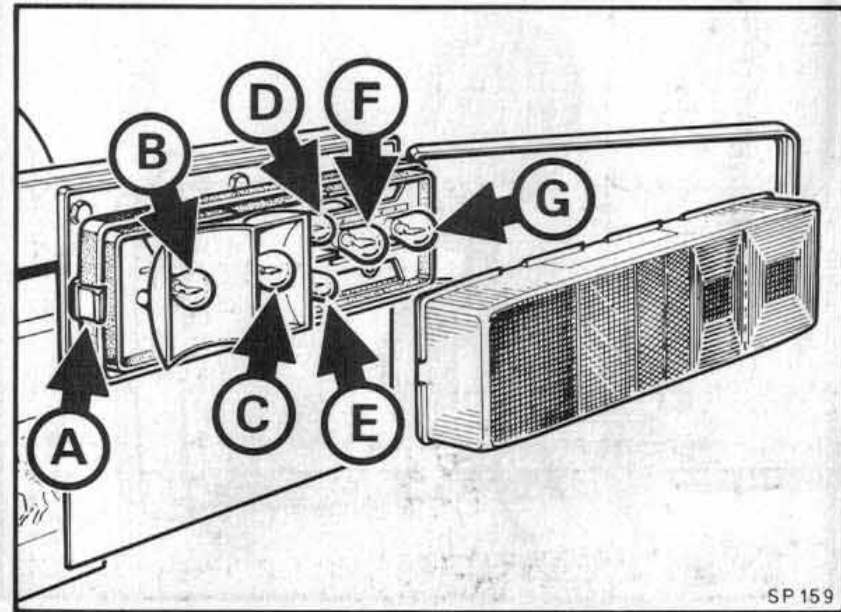

Truck right hand rear lamp

Rear Lamps - Van Model

To renew the bulbs it is necessary to remove the lens. Note that the stop/tail bulb has off-set pins to ensure correct fitting.

- A - Direction indicator
- B - Stop/tail light
- C - Reverse light
- D - Fog light
- E - Number plate light

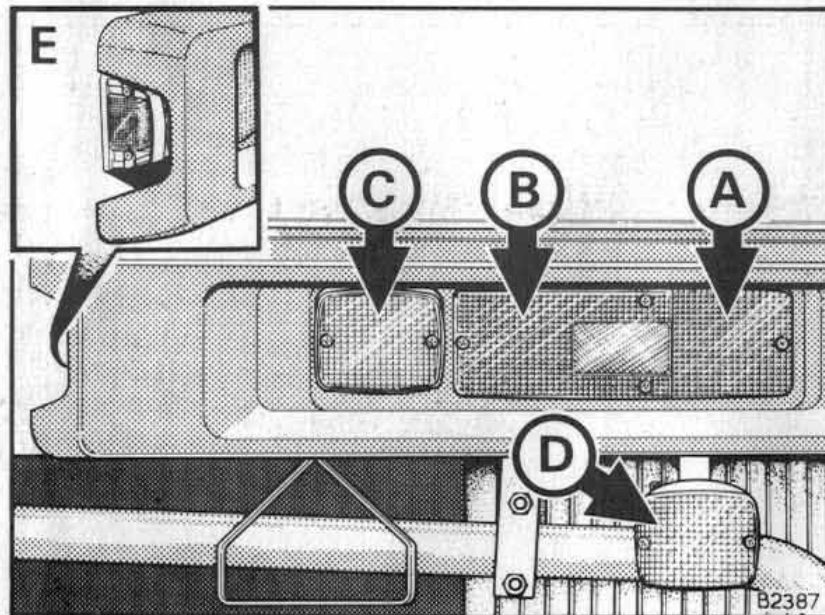

Van right hand rear lamp

Heater Control Panel Illumination

Removal and replacement of these bulbs necessitate the removal of the rear engine cover, the auxiliary fascia panel surrounding the heater control panel, face level vents and air ducts, the heater control bracket and finally the bulbs from their holders.

We recommend that you have this work carried out by your dealer.

Warning and Instrument Lights

Warning light bulbs are retained in press fit plastic holders behind the light symbols and instrument light bulbs in push fit holders in the backs of instruments.

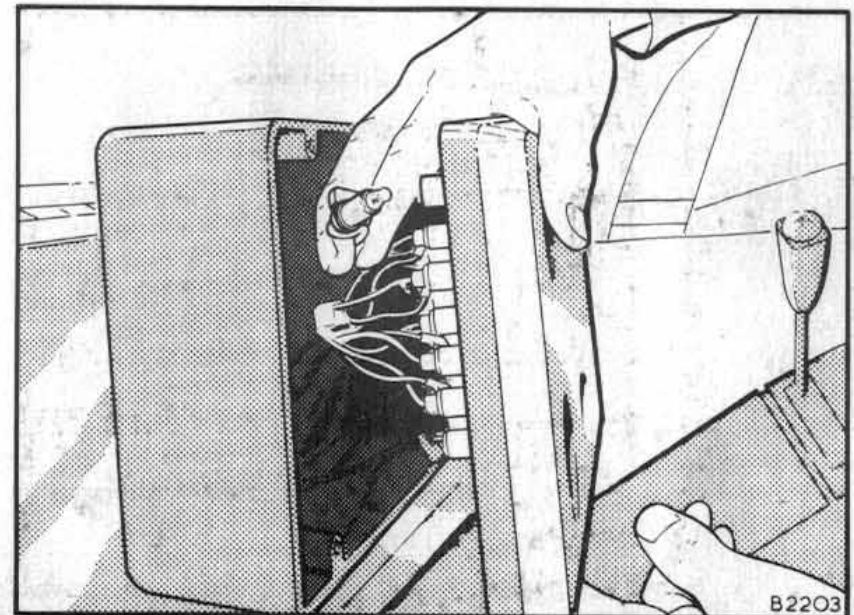

Warning and instrument lights

RENAULT

Trucks

Renault Truck Industries Limited,
Aftersales Operations,
Elmdon Trading Estate,
Bickenhill Lane,
Birmingham B37 7HE.

Printed in England. RTI 10-1988.